

# MTL Surge Technologies

## Earthing guide for surge protection

### Synopsis

This publication discusses the major aspects of earthing surge protection devices (SPDs). The relationship between SPD earths and the earthing of associated instrumentation or other equipment with which the devices are used is also considered.

## Application Note TAN 1003

## Application Notes from MTL Surge Technologies

MTL Surge Technologies publish an increasing number of Application Notes providing easily understood information on various aspects of lightning and surge protection. At the date of publication of this Application Note, the list included:-

- TAN1001** Lightning surge protection for electronic equipment – *a practical guide*  
A relatively brief and easy to understand introduction to the subject – an excellent starting point.
- TAN1002** Lightning and surge protection – *basic principles*  
A more detailed account of the mechanism of lightning strikes and the measures needed to achieve an adequate level of protection.
- TAN1003** Earthing guide for surge protection  
A detailed analysis of the subject of earthing for surge suppression purposes, this is both an easily understood exposition and a valuable reference document.
- TAN1004** Surge protection for intrinsically safe systems  
A description of the best methods of combining surge protection and intrinsically safe systems.
- TAN1005** Surge protection for Zone 0 locations  
A detailed analysis of this particular aspect of surge suppression in hazardous areas; complements TAN1004.
- TAN1006** Surge protection for weighing systems  
Discusses, in some detail, the application of surge suppression to load-cell weighing systems.
- TAN1007** Surge protection for Local Area Networks  
Discusses ways in which Local Area Networks can be damaged by lightning induced transients and how they can be protected economically.
- TAN1009** Surge protection for electrical power installations  
Discusses aspects of how to protect and install mains devices, with information on earthing and mains systems. A guide to simple maintenance techniques for surge protection devices is included.

## About MTL Surge Technologies

MTL Surge Technologies, the surge protection division of the MTL Instruments Group Plc, designs and manufactures a vast range of protection solutions for all your system surge protection requirements. Comprising of two independent but closely linked companies, Telematic and Atlantic Scientific Corporation, MTL Surge Technologies has a combined experience of nearly 50 years within the surge protection industry. MTL Surge Technologies supplies a wide range of Telematic and Atlantic Scientific surge protection devices offering solutions for all AC power, data and signal, telecom, network and wireless and HF systems.

The MTL Instruments Group has a strong and well respected presence within the Industrial Process market. This, combined with Telematic's close association with the Water Industry and Atlantic Scientific's presence in the Networks and Wireless Infrastructure market, means that MTL Surge Technologies is well placed to support a wide range of industries around the world.

<b>1</b>	<b>EARTHING FOR SURGE PROTECTION OF ELECTRONIC EQUIPMENT</b>	
1.1	Introduction .....	1
1.2	Practical aspects of surge protection earthing – summary .....	1
<b>2</b>	<b>LIGHTNING – AND THE NEED FOR SURGE PROTECTION .....</b>	<b>2</b>
2.1	The threat from lightning transients .....	2
2.2	How lightning interacts with electronic systems.....	2
2.3	Lightning surges – how big.....	3
2.4	What do we mean by ‘earth’?.....	3
2.5	Earthing problems – basic questions.....	3
2.6	Complete protection – box it!.....	3
2.7	An idealised earthing system – next best thing to a metal box.....	4
2.8	A less than ‘ideal’ system.....	4
2.9	Recapitulation – the threat from lightning.....	4
<b>3</b>	<b>SURGES AND SURGE PROTECTION.....</b>	<b>5</b>
3.1	Common and difference mode surges.....	5
3.2	How surges damage equipment .....	5
3.3	Surge protection devices (SPDs) – how they work.....	5
3.4	What equipment needs protecting?.....	6
3.5	Case study – telephones, answering machines and modems .....	6
<b>4</b>	<b>EARTHING FOR SURGE PROTECTION IN THE ‘REAL WORLD’.....</b>	<b>6</b>
4.1	Introduction – earth impedance and position.....	6
<b>5</b>	<b>SURGE EARTH IMPEDANCE .....</b>	<b>7</b>
5.1	Inductance and resistance .....	7
5.2	A note on ‘skin depth’ .....	8
5.3	Inductance and surges – another angle .....	8
5.4	Surges on cables – some real measurement .....	8
5.5	Inductance – recapitulation .....	9
<b>6</b>	<b>SURGE EARTH POSITION .....</b>	<b>9</b>
6.1	The trouble with a high impedance surge earth .....	9
6.2	Re-positioning the earth connection to lower the limiting voltage .....	9
6.3	Using a ‘surge link’ when the earth connection cannot be repositioned .....	10
<b>7</b>	<b>EARTHING SYSTEM CONFIGURATIONS AND INSTALLATION .....</b>	<b>10</b>
7.1	Star-point earthing .....	10
7.2	Implementing a star-point earthing system .....	11
7.3	Surge earths and protective earths .....	11
7.4	Surge protection for external connections .....	12
7.5	Cable layout problems associated with cables entering a building at separate points .....	13
7.6	Ground electrodes, ground impedance and surges .....	14
7.7	Connection to the structural lightning protection system .....	15
7.8	The other end of the cable .....	15
<b>8</b>	<b>MISCELLANEOUS TOPICS .....</b>	<b>16</b>
8.1	Shielded cables and earth loops .....	16
8.2	Protecting baseband transmission systems using co-axial cable .....	17
8.3	Protecting high-frequency co-axial cable systems (e.g. antenna feeds and CCTV) .....	17
8.4	Protecting the mains supply .....	18
8.5	Surge earths and telecommunications functional earths .....	19
8.6	Integrated earthing for process systems .....	19
8.7	Hazardous areas – earthing for lightning protection .....	19
<b>9</b>	<b>APPENDICES .....</b>	<b>21</b>
9.A	Appendix A – Ground electrode resistance and surge current sharing, a simple model .....	21
9.B	Appendix B – Glossary .....	22
9.C	Appendix C – Further reading .....	22

# EARTHING GUIDE FOR SURGE PROTECTION

## 1 EARTHING FOR SURGE PROTECTION OF ELECTRONIC EQUIPMENT

### 1.1 Introduction

At MTL Surge Technologies, we believe it is possible to provide economic and practical surge protection for virtually all electronic systems. However, the protection provided depends crucially on the quality of the installation – the best surge protection device is of no use if incorrectly installed. Installation – and more specifically earthing – is the subject of many technical queries.

This Application Note is an attempt to share the expertise on earthing and installation built up over the years to assist you in specifying or installing

systems requiring lightning protection. Much of our experience has been gained in co-operation with customers, to whom we are grateful, and we are only too pleased to take note of your views and comments to improve future editions of this publication.

We have tried to be as clear as possible and to de-mystify a subject regarded as a 'black art' by many. In fact, a good understanding can be gained using concepts from basic electrical theory only. It is appreciated that you may well encounter practical difficulties outside the scope of this publication (in which case, our technical consultancy service may prove of value) but we also believe that knowledge of the underlying principles is always helpful for tackling real-life problems.

To make sure the specialist terminology used in surge protection is understood – a short glossary is included as Appendix B.

### 1.2 Practical aspects of surge protection earthing – summary

This section briefly summarises what needs to be done to earth surge protection devices effectively while the rest of the publication explains why.

#### 1.2.1 Structural protection

Make sure the building housing the equipment is provided with structural lightning protection in accordance with national standards (in the UK, these are established by BS6651).

#### 1.2.2 Cable routing

If possible, bring all services (i.e. electricity, telephone, LAN cables, antenna cables, metallic water and gas pipes) into the building at one point.

#### 1.2.3 Bonding and earthing

Bond the following services to an earth terminal at one point (preferably the main distribution board for the mains electrical supply where applicable) using as short a bond cable length as possible, to keep them as close as possible to the same potential:-

- ◆ Metallic water and gas pipes
- ◆ Antenna cable

Bond this earth terminal to the building structural lightning protection as close to the ground as possible.

#### 1.2.4 Surge protection

Fit, as close to the earth terminal as possible, appropriate surge protection devices (SPDs) on ALL incoming cables, where applicable, for the following services:-

- ◆ Electricity
- ◆ Telephone
- ◆ Local Area Network
- ◆ Antenna
- ◆ Video (security) camera

Bond the SPDs to the earth terminal with the shortest possible length of cable with a minimum cross section of 2.5mm<sup>2</sup>. Better still, use several cables, spaced apart and connected electrically in parallel.

Best of all, use sheet metalwork rather than cables.

If you own the entire cable link, fit another SPD at the remote end.

#### 1.2.5 Diverse cables which cannot be rerouted

Fit appropriate SPDs close to the most strategically important equipment (e.g. fax machines, modems, etc.)

Bond the SPDs to the equipment earth (e.g. chassis or mains protective earth) with the shortest possible length of cable with a minimum cross section of 2.5mm<sup>2</sup>. Better still, use several cables, spaced apart and connected electrically in parallel. Best of all, use sheet metalwork rather than cables.

## 2 LIGHTNING – AND THE NEED FOR SURGE PROTECTION

### 2.1 The threat from lightning transients

Lightning is a fascinating natural phenomenon – which we can discuss only briefly in this publication. However, Appendix C, 'Further Reading' lists some excellent sources of more information.

Briefly, a lightning flash is caused by an electrical current flowing in the atmosphere. Moist air currents interacting with ice particles within a cloud lead to the formation of concentrations of electric charges at different heights. Very large voltage differences, of the order of many millions of volts, develop between the charge concentrations and the base of the cloud and the surface of the earth. When this voltage difference becomes sufficient to overcome atmospheric resistance, a lightning stroke occurs. Most lightning strokes take place cloud-to-cloud but some are cloud-to-ground.

In the UK, it is believed that 98% of direct cloud-to-ground strokes carry a current of 200kA or less, with a median of around 30kA.

### 2.2 How lightning interacts with electronic systems

There are a number of ways in which lightning can interact with electronic equipment:–

- By a direct strike from a cloud-to-ground lightning stroke, sometimes referred to by the archaic-sounding description of 'direct attachment' (see 2.2.1)
- Electric/magnetic coupling, also referred to as capacitive/inductive coupling, from cloud-to-cloud or cloud-to-ground lightning (see 2.2.2).
- Ground potential surges caused by a cloud-to-ground strike and sometimes referred to as 'resistive coupling' (see 2.2.3).

In practice, during a cloud-to-ground strike, various combinations of these coupling mechanisms may occur simultaneously.

### 2.1 Direct attachment

This describes a direct strike to the equipment or, more usually, the building or plant housing it (figure 1). The effects of this can be devastating, due to the enormous currents and energies involved. Where there is a significant risk of a direct strike, external structural protection based on lightning conductors and earth rods is essential to provide a relatively easy path for lightning current to flow into the ground without entering the building. Without external protection, equipment housed in the building may provide the easiest path to earth for lightning currents via 'side-flashing' where the lightning arcs across from the outside to the inside, damaging the structure in the process. However, even well-protected structures pose problems for internal equipment as the lightning currents passing into the ground may create ground potential surges (see 2.2.3).

### 2.2.2 Electric/magnetic (capacitive/inductive) coupling

A highly-charged thundercloud sets up a very large electric field to ground. When a lightning discharge occurs, this electric field changes very rapidly and can couple a voltage spike into equipment cables due to cloud-to-cable capacitance. Simultaneously, huge currents (tens to hundreds of kiloamps) flow, which can couple transient currents into cables through mutual inductance. However, field induction is the weakest of the coupling mechanisms and is not generally regarded as a significant source of damage.

Note 1: When the lightning current flows, an electromagnetic field is set up, producing crackles, particularly on long and medium wave radios. Some organisations monitor lightning activity with radio techniques which can be used to record the location and severity of strikes.

### 2.2.3 Resistive coupling and ground potential surges

When lightning strikes the ground (figure 1), the current disperses through the soil. Because the ground is not a perfect conductor, high voltages can develop. Two buildings, and the equipment which they contain, can therefore be at very different local ground potentials. If cables, buried or not, link them, the equipment at each end will be subjected to this potential difference. This is a common source of damage (see figure 2). The ground potential surge will be most severe in the case of a direct strike (see 2.2.1). Although direct strikes cause the most damage, the ground potential surge poses the greatest threat to electronic equipment, because the probability of it happening is much higher.

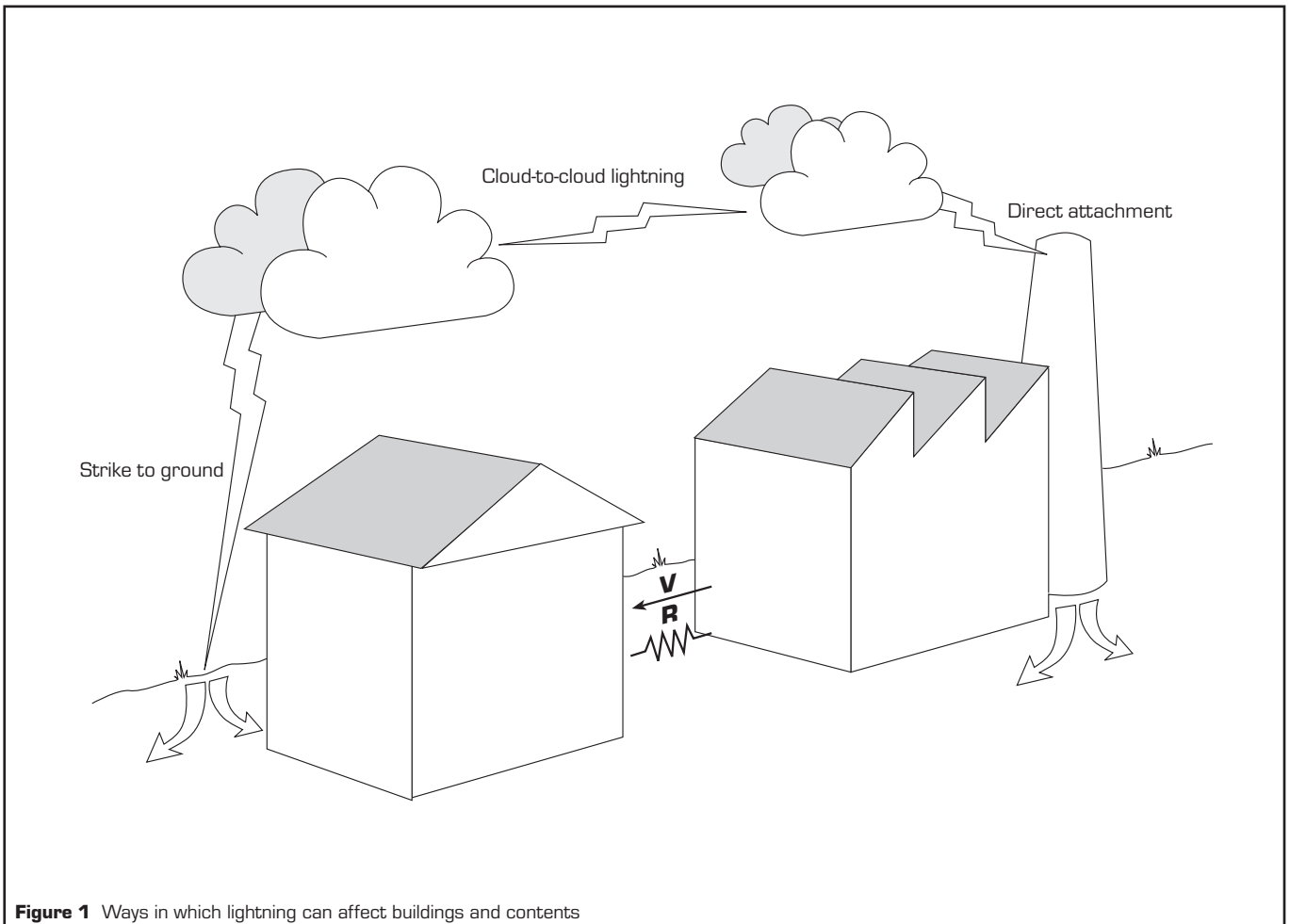
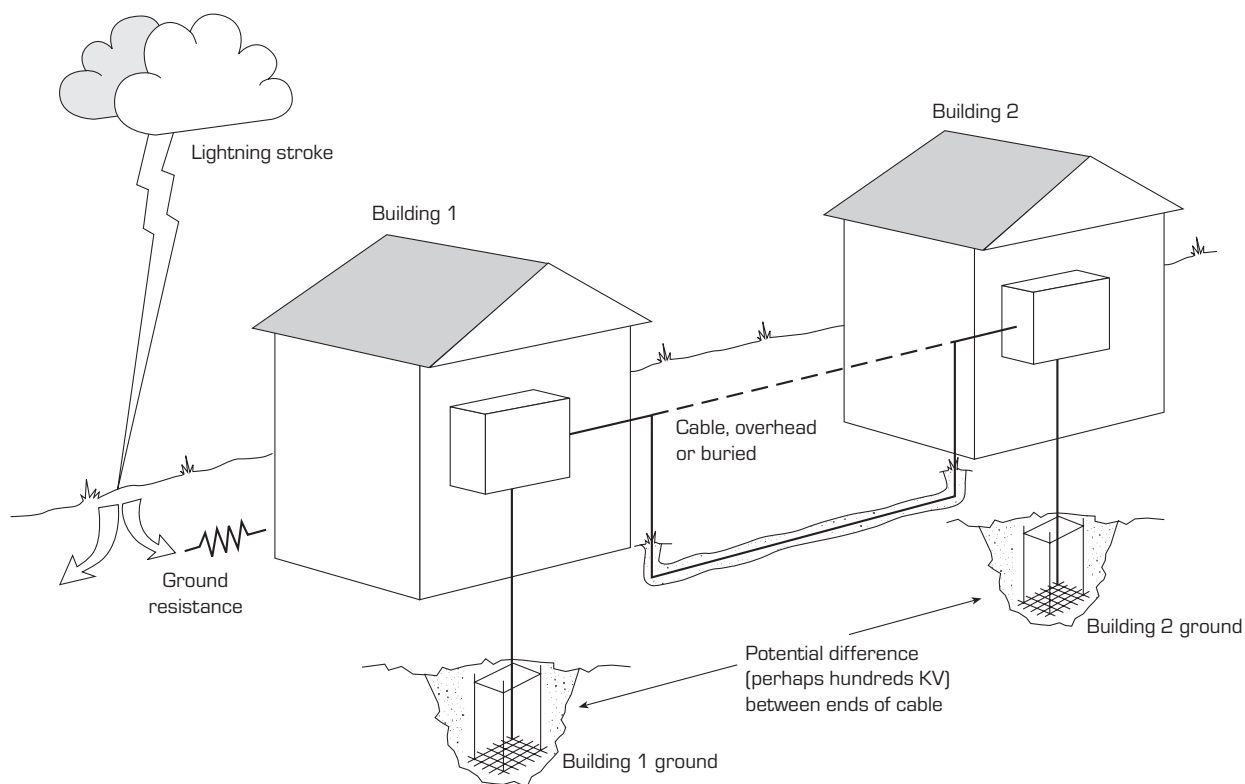

Figure 1 Ways in which lightning can affect buildings and contents



**Figure 2** Mechanism of ground potential surge caused by a cloud-to-ground strike

### 2.3 Lightning surges – how big?

Fortunately, in the vast majority of cases, only a fraction of the full effects of a direct lightning strike affect equipment cables. Experience suggests that most surge protection devices will be effective if they can cope, repeatedly, with the following orders of magnitude:-

- a) Voltage: kilovolts to tens of kV
- b) Current: kiloamps to low tens of kA
- c) Duration: 10 to several hundred microseconds

Before covering the threat from lightning in more detail, we need to sort out a few terms and definitions concerning 'earths' (section 2.4).

### 2.4 What do we mean by 'earth'?

'Earthing' can seem a bewildering subject – partly because even in the restricted electrical sense of the word, it can mean different things to different people. Even without considering all the 'extremes', here are just a few:-

- a) Process plant clean earth
- b) A copper ('OV') track on a printed circuit board
- c) Supply earth
- d) Earth pin of a mains plug
- e) Common negative
- f) Antenna earth system (e.g. a set of buried radials)
- g) Distribution earth
- h) Surge earth
- i) Intrinsic safety earth
- j) Busbar in a panel or cubicle
- k) A connection to test equipment (e.g. oscilloscope) front panel
- l) A conductive rod driven into the ground

#### 2.4.1 EARTH – a simple working definition

In this Application Note, 'earth' is defined as the zero volt reference for an electrical/electronic system.

Note 1: There is no such thing as 'true earth', i.e. a universal 'zero volt reference'.

Note 2: In this publication, the term 'ground' is applied to the surface of the planet, i.e. soil and rock. As sometimes happens with terminology, what is referred to as 'earth' in the UK is referred to as 'ground' in North America and vice-versa.

Note 3: Many real-world systems need a connection to the ground. Mains power is an example. Lightning being an interaction between the atmosphere and the ground, these systems may need protection.

Note 4: Self-contained electronic products such as battery- or solar-powered devices such as radios, calculators and personal cassette players are isolated from ground and for them, therefore, the issue of earthing is irrelevant.

Note 5: 'Earth' has also been defined as 'the place to which electrons go at the end of their useful lives'. In fact, 'old electrons never die' – most having been around since the early universe. They are thus extremely aged and deserve our utmost respect.

### 2.5 Earthing problems – basic questions

Earthing problems can seem impenetrable at first sight – but this need not be so provided two basic questions are borne in mind at each stage:-

- a) Where will current flow?
- b) What voltage (or 'potential difference') will develop when it does?

Answering these questions is the object of much of this publication. Remember also that:-

- c) Lightning-induced current will ultimately flow to ground, i.e. into the soil.
- d) When tackling a new installation, a diagram or sketch is usually valuable.

### 2.6 Complete protection – box it!

If the entire electronic system can be enclosed in an electrically conducting (e.g. 'metal') box, unwanted currents flowing round the outside of the box will not generate any potentials inside (see figure 3). This is the principle of the so-called 'Faraday cage'. Electronic equipment inside such a box will survive even a direct strike.

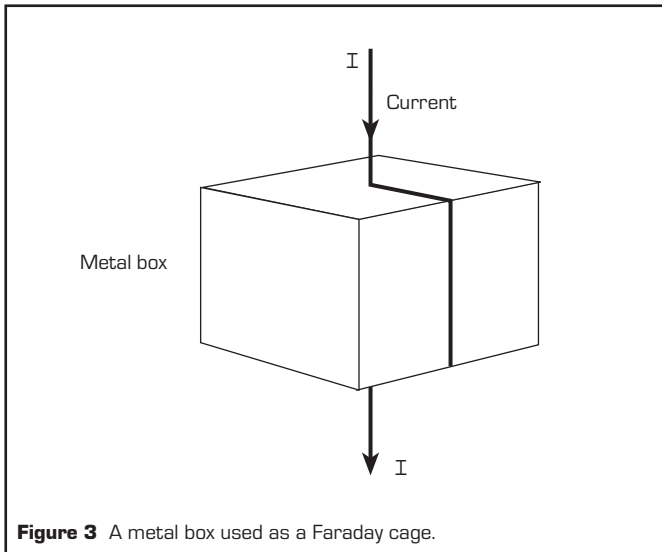

**Figure 3** A metal box used as a Faraday cage.

Although at first sight this concept may seem trivial, in aviation it is very important. Aircraft designers strive to make airframes as closely approximate to 'closed metal boxes' as possible. In regular service, passenger aircraft expect to be struck by lightning at least once a year on average. A great deal of modelling and testing is undertaken to make sure avionic equipment survives lightning strikes unscathed.

A word to the wise – this shielding effect of a metal enclosure means it is safer to remain within a metal-bodied car during a thunderstorm than to leave it.

### 2.7 An idealised earthing system – next best thing to a metal box

When confronted with a real-life lightning protection problem, it is helpful to bear an 'ideal next best thing to a metal box' solution in mind, in order to reach the closest practical approximation to this.

This 'ideal' system, which virtually eliminates problems with surges – is shown in figure 4. Salient points are:-

- a) All equipment is metal-cased.
- b) All equipment sits directly on a metal sheet to which it is electrically bonded. Everything shares the same low-impedance zero volt reference.
- c) For good measure, the metal 'earth plane' is at ground level and connected to ground by a system of rods driven into the soil so that it is at local ground potential.
- d) There is no connection to other electronic systems.
- e) The system is physically small, a few square metres at most, so making the likelihood of a direct strike negligible.

The purpose of the metal 'earth plane' sheet is to provide a low impedance to any induced currents which flow, resulting in very small induced voltages. Such an area of zero or minimal potential differences is sometimes referred to as an 'equipotential zone'

It is worth explaining what is meant by 'low impedance'. This is a loose term and the meaning depends a great deal on the context and application. With lightning-induced surges, currents of the order of 1 kiloamp may be involved, developing a potential difference of 1 kilovolt across each ohm of impedance for each kiloamp of current which flows.

The lowest impedance is provided by a sheet of 'high-conductivity' metal – which, strictly, should be non-ferrous because of the skin effect which is more pronounced in ferro-magnetic alloys and which forces transient or high-frequency currents to flow through smaller conductor areas. Skin effect is also mentioned in section 5.2 with reference to surge earth impedance.

For a 50-60Hz electrical supply, the purpose of the protective earth conductor is to provide a 'low impedance' to supply frequency fault currents, so that voltages developed across a length of cable are insufficient to cause a serious electric shock to any people within the installation. Metal plumbing and heating pipes are bonded to the protective earth conductor system to create a safe equipotential zone. However, as we shall see, this system, though adequate at the supply frequency, cannot be considered a low impedance equipotential zone for lightning-induced transients.

### 2.8 A less than 'ideal' system

We still have our excellent grounded earth plane, but, as in figure 5, our equipotential zone is now breached by cables coming in from outside. These could be for:-

- a) Mains power
- b) Telephone
- c) Telemetry
- d) Antennas
- e) Computer network
- f) External lighting power cables

Now that we have a system of cables, we do need to worry about lightning-induced transients and it is time to evaluate in more detail (see section 3) the way in which cables can pass transients to our equipment and the means by which surge protection devices operate.

### 2.9 Recapitulation – the threat from lightning

- a) Lightning strikes to ground involve large currents (averaging tens of kiloamps (kA).
- b) Because the ground (i.e. soil and rock) is not a perfect conductor, lightning current flowing through the ground resistance develops very large voltages (hundreds of kilovolt (kV) or more) between points on the Earth's surface.

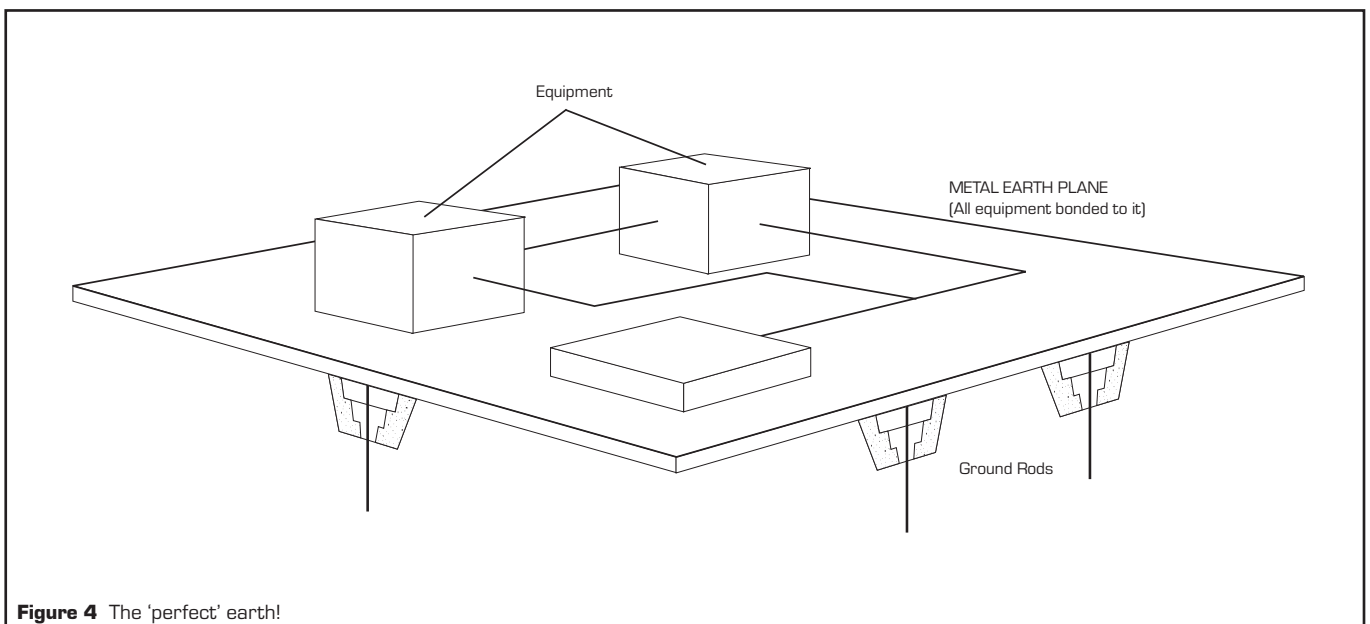

**Figure 4** The 'perfect' earth!

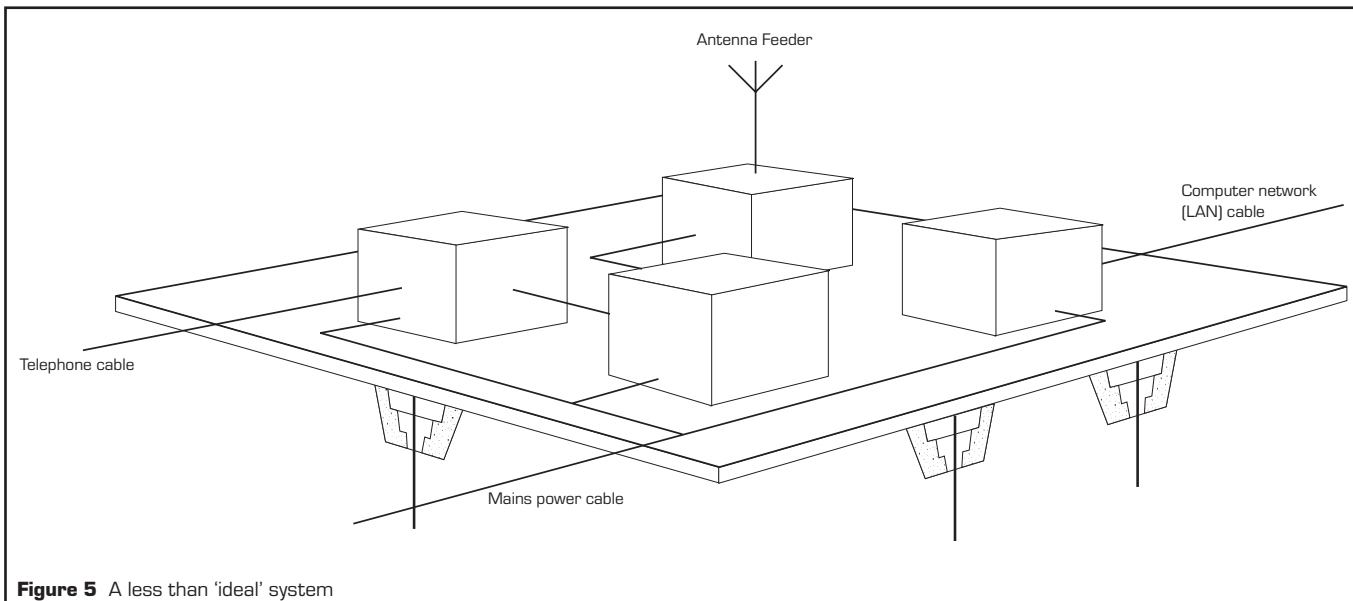

**Figure 5** A less than 'ideal' system

- c) Such points could be two buildings containing electrical installations and linked by cables; a strike close to one (say within 1km) raises the potential of the ground and a large potential difference develops between the two installations.
- d) A surge has been created; if current flows (as it generally will when there is an enormous potential difference between the two installations), the ultimate damaging current path is between the ground connections of the two installations.

### 3 SURGES AND SURGE PROTECTION

#### 3.1 Common and difference mode surges

Cables consist of more than one conductor. During a surge, all conductors will tend to move together in potential relative to local ground. This is referred to as common mode (figure 6).

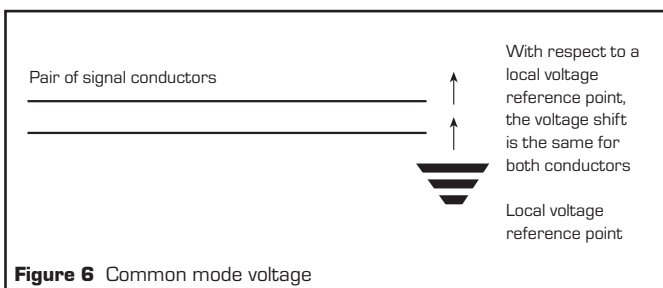

**Figure 6** Common mode voltage

However, a difference in voltage can also develop between the conductors. This is referred to as 'difference mode' (also known as 'transverse' or 'series' mode) – (figure 7).

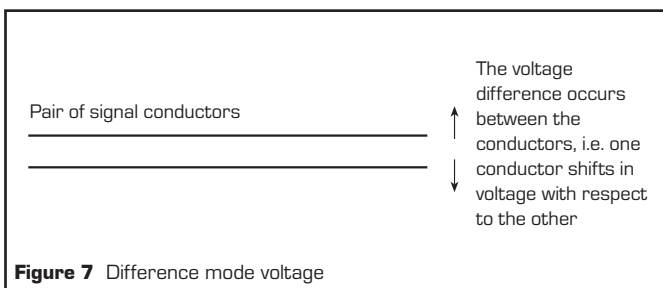

**Figure 7** Difference mode voltage

Both can damage equipment. Common mode surges tend to be bigger, but equipment tends to be more vulnerable to difference mode. However, Telematic protectors limit both types of surge.

#### 3.2 How surges damage equipment

Before a surge can damage electronic equipment, several conditions need to be fulfilled:-

#### 3.2.1 Voltage/current relationship

Sufficient voltage must be present between two vulnerable points on the equipment to cause significant current to flow. The vulnerable points are usually signal or power supply inputs or outputs, and the equipment's zero voltage reference point which is commonly the casing or chassis connected to the mains supply earth. The voltage above which significant current starts to flow is often called the breakdown voltage (or potential).

#### 3.2.2 Time/energy relationship

The current must flow for sufficient time to deposit enough energy within electronic components to cause damage – commonly the melting down of some part of the device.

#### 3.3 Surge protection devices (SPDs) – how they work

Surge protection devices (see the glossary – Appendix B for other commonly-used terms for these) limit the transient voltage to a level which is safe for the equipment they protect by conducting the large surge current safely to ground through the earth conductor system. Current flows past, rather than through, the protected equipment and the SPD thereby diverts the surge (see figure 8).

The SPD limits both common and difference mode voltages to the equipment. The voltage which the equipment receives during a surge is called the 'limiting' or 'let-through' voltage.

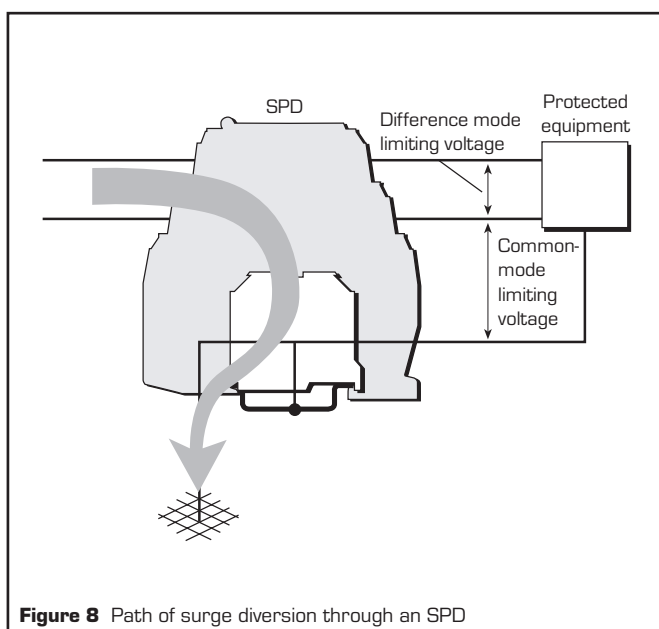

**Figure 8** Path of surge diversion through an SPD

One way of regarding a surge protection device is as an earth connection (figure 9) which is only present during a surge.

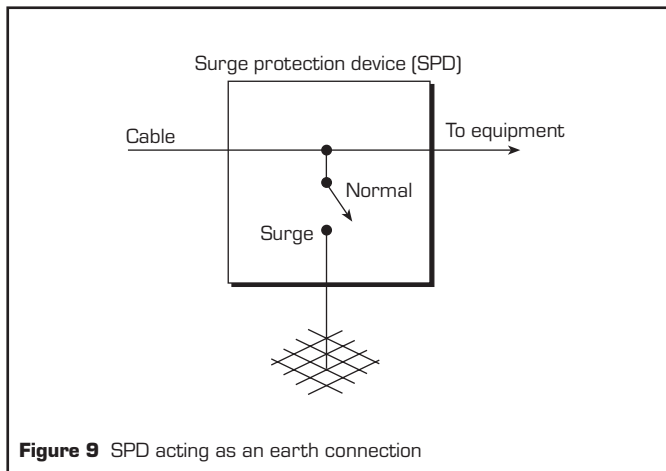

Figure 9 SPD acting as an earth connection

### 3.4 What equipment needs protecting?

In principle, wherever a cable enters an equipotential zone, equipment connected to that cable is exposed to possibly damaging surges. The degree of risk depends on factors such as:-

- a) Cable length.
  - b) Frequency of occurrence of lightning.
  - c) Exposure of the site to lightning and the degree of isolation.
  - d) Whether cables run above ground or underground.
- It is essential to protect ALL cables which introduce a significant risk, as will be seen later.

Consider again our system on its earth plane, but now with all incoming cables (figure 10) feeding equipment through suitable SPDs. Because of the low impedance earth plane, this will still be close to an ideal system.

Note 1: Small, self-contained, isolated pieces of equipment, e.g. multimeters, transistor radios and cassette players, do not, in general, need protecting, because they do not have a ground connection.

### 3.5 Case study – telephones, answering machines and modems

This case study illustrates points made in the previous sections in part 3. While it is based on UK practice, the points it makes have a general application.

For decades until quite recently, the only communication device in the home was the telephone, connected to the public telephone network (PTN) by a wire-pair. A telephone was powered from the network and had no electrical connection to the house. Being electrically isolated, it was therefore not

vulnerable (apart from rare direct strikes to the house) to common mode transients on the telephone wires. Protection from difference mode transients was given by a gas-discharge tube (GDT) fitted in the house line-box. Although the limiting voltage of the GDT can be several hundred volts for the first microsecond or so of the transient, this was generally adequate – difference mode voltages of up to 180V or so can occur during normal operation.

Next came answering machines and, more recently still, modems linking personal computers to the Internet through the telephone connection. These are powered from the house electrical mains. They are isolated up to a point by the primary to secondary insulation in the power supply transformer. However, a lightning transient can create a common mode voltage sufficient to break down this insulation and the circuit components. A current path is created between the telephone line and the mains supply, and damage to the answering machine or modem is the result.

Note that even though double insulation is normally used, with no direct connection to the mains protective earth conductor; this is of little consequence when a transient voltage of several kilovolt occurs. In any case, neutral and earth conductors are bonded at some point on the supply (in modern installations at the point where the mains supply enters the building).

To recapitulate, damage is caused by the presence of a voltage difference between the telephone wires and local earth, in this case the electrical mains, which is sufficient to overcome the breakdown potentials of the power supply and the equipment. Current flows through the telephone line, equipment and power supply to the mains supply for sufficiently long to deposit enough energy within the components to cause damage. Ultimately, the current flows into the ground where the mains supply has its connection with the soil.

## 4 EARTHING FOR SURGE PROTECTION IN THE 'REAL WORLD'

### 4.1 Introduction – earth impedance and position

In reality, very few systems are bonded to an earth plane or mat. 'Real' earthing is done with cables. Think of the all-important two questions:-

- a) Where will the surge current flow?
- b) What voltage ('potential difference') will develop when it does?

The answer to these questions in any particular case depends on the position and impedance of the surge earth.

#### 4.1.1 Example

The use of separate connections to ground, such as separate ground rods, can cause unwanted voltages to be developed across the ground impedance (figure 11). These can be appreciable.

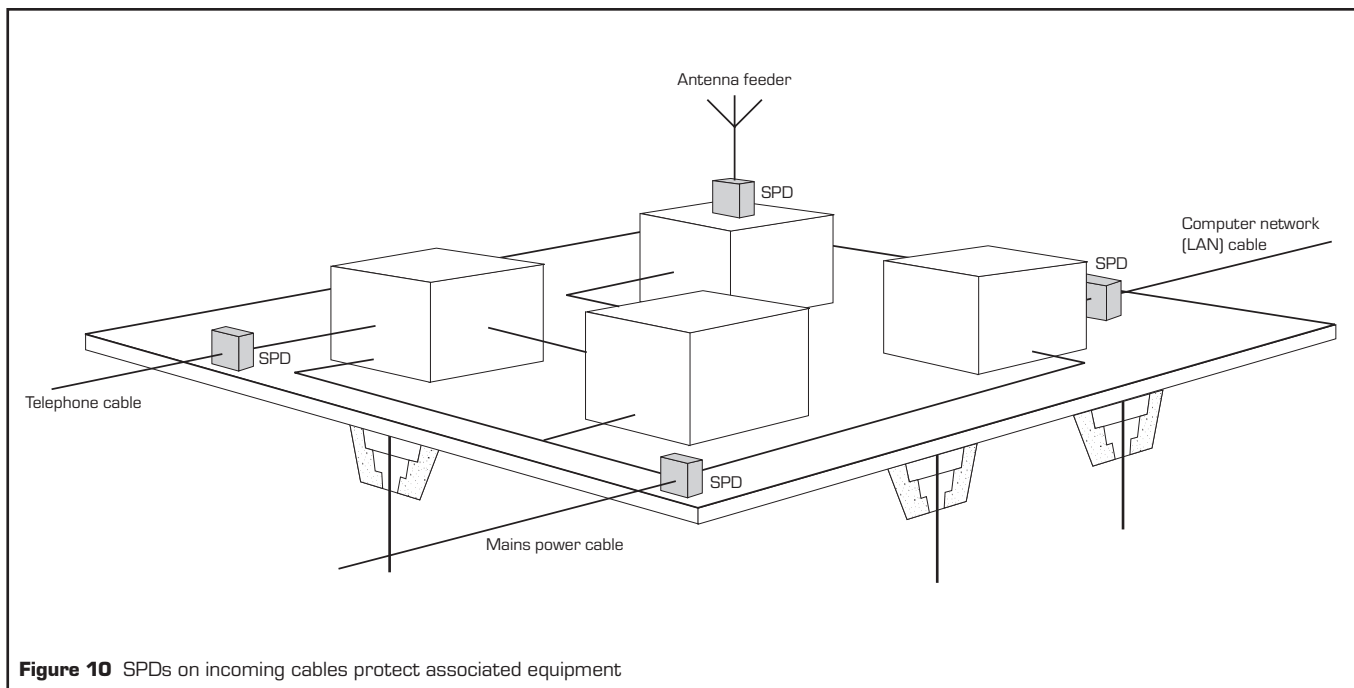
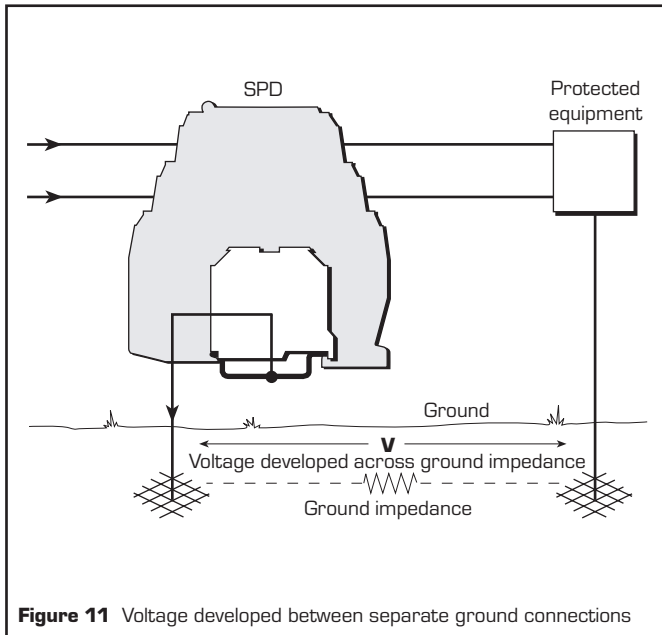

Figure 10 SPDs on incoming cables protect associated equipment



**Figure 11** Voltage developed between separate ground connections

Assume an SPD with a limiting voltage of 16V is connected as shown in figure 12 and that the impedance from the body of the SPD to the equipment earth, via the ground, is 10Ω. Depending upon the soil and other circumstances, this can be a credible low value.

A 100A peak surge current flowing through the ground impedance will develop 1000V through the ground. The SPD will limit the voltage across itself to 16V and the equipment will be subjected to 1016V instead of the required 16V. Damage to the equipment is inevitable! Fortunately, it is possible to improve on this as we shall see after studying 'impedance' a little more closely.

## 5 SURGE EARTH IMPEDANCE

### 5.1 Inductance and resistance

Conductors possess resistance and inductance [see reference 4]. The effects of these (figure 12) are additive as they appear in series.

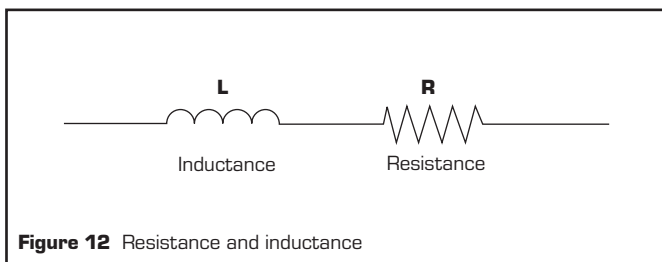

**Figure 12** Resistance and inductance

The voltage drop along this cable is given by:-

$$V = IR + L \frac{dI}{dt}$$

where V = voltage, I = current, R = resistance, L = inductance and  $\frac{dI}{dt}$  = rate of change of current.

For low frequencies, such as 50Hz mains supplies, inductance is usually negligible in practice and only resistance needs be considered.

Resistance depends on the material used for the conductor. For any given material of uniform cross section, it is proportional to length and inversely proportional to the cross sectional area, i.e.:-

$$R = \rho l / A$$

where R = resistance in Ω, ρ = resistivity in Ω.m, l = length in m and A = cross sectional area (m<sup>2</sup>).

For lightning surges, and even more so for electrostatic discharges (ESD), which have extremely fast edges, inductance dominates. An earth which is adequate for the normal mains supply frequency, may not be so for lightning surge protection.

Inductance is more complicated than resistance. The formula for the inductance of a straight piece of wire is:-

$$L = 0.2l \{ \log_e \frac{2.1}{r} - 1 \} \mu H$$

where l = length and r = radius (both in m)

Note: In most cases, the wire will be much longer than it is thick, and its inductance decreases only slightly as the diameter increases. However, the inductance goes up even faster than the length, as table 1 shows. This is based on a peak surge current of 1kA, with a maximum rate of rise of 100A/μs, flowing through copper cable. This represents a result that can happen in practice and is by no means an extreme case.

**Table 1**

Length (m)	Cross section (mm <sup>2</sup> )	Resistance (Ω)	Inductance (μH)	Peak resistive voltage (V)	Peak inductive voltage (V)
1	1	0.017	1.4	17	144
1	2.5	0.0068	1.3	6.8	134
1	10	0.0017	1.2	1.7	120
10	1	0.17	19	170	1895
10	2.5	0.068	18	68	1803
10	10	0.017	16.6	17	1664

Note: The peak resistive and inductive voltages are not added together to give a total voltage, because they do not occur at the same time. The resistive voltage peaks with the current. However the inductive voltage peaks when the rate of rise of current is maximum. At the peak of the current waveform, the rate of rise of current (by definition) is zero and so is the inductive voltage.

A number of important points emerge from table 1:-

- The inductive voltage dwarfs the resistive voltage.
- Resistance is proportional to length; but inductance grows at a somewhat faster rate (e.g. a 10m wire has more than 10 times the inductance of a 1m wire).
- Wire diameter has a relatively small effect on the inductance. For instance, increasing wire size from 2.5 to 10mm<sup>2</sup> (doubling the diameter) reduces inductance by less than 10%. The larger cable is much more difficult to bend, strip and install. However, if the mechanical strength of a larger cable is needed, use it.

In conclusion - keep all surge earth cables as short as possible!

We usually recommend cable of 2.5mm<sup>2</sup> minimum cross-section for the surge earth. This is large enough not to overheat or melt during any likely surge (and is unlikely to be the weak link in any case), yet it is convenient to handle and install. However, as noted elsewhere, mechanical strength or other circumstances may favour the use of thicker cables.

Note: As a 'rule of thumb', for cables up to a few metres in length; at least 100V is developed per metre of surge earth cable, per kiloamp of lightning-induced surge current; i.e. 100V/m/kA. This is based on a rate of rise of current of 100A/μs. Calculation based on a 1m length of 2.5mm<sup>2</sup> cable and the '8/20μs' current pulse test waveform (see section 5.4) gives 200V/kA.

Note: The inductive voltage transients are common-mode. Telematic surge protection devices have very low internal inductance values which means that difference-mode transients are limited effectively regardless of the earth cable.

## 5.2 A note on 'skin depth'

High frequency current flowing through a conductor generates an electromagnetic field, one effect of which is to confine the current towards the outside of the conductor. This is known as the 'skin effect' while the thickness of the layer to which most of the current is restricted is the 'skin depth'. The higher the frequency, the smaller the depth. Consequently, because not all of the conductor's cross section is carrying its fair share of current, the resistance is higher than its direct current value.

For a copper conductor at 50Hz, skin depth is of the order of 10mm, so is seldom a problem. However, lightning transients induced on cables have considerably higher frequency components (up to the order of tens of kHz) in which case the skin depth – which is proportional to the square root of the inverse of the frequency – in copper is less than 1mm.

The skin effect will cause the resistive voltages to be greater than those shown in table 1. However, we believe this will less than double the resistive voltage. Since this is still dwarfed by inductance, the argument that length is more important than diameter holds good and, in fact, is reinforced. The skin effect simply means that some of the benefit of increasing the diameter of a conductor is lost.

## 5.3 Inductance and surges – another angle

Inductors store energy in the form of a magnetic field. If the voltage transient is large enough to cause surge current to flow in the equipment, this energy is released to cause damage. The energy (E) stored in an inductor of inductance L, is given by:-

$$E = L \cdot I^2/2$$

where I is the peak current.

If we again consider the case of 1kA peak current and the inductance of a 2.5mm<sup>2</sup> cable obtained from table 1, we find the results shown in table 2:-

**Table 2**

Length (m)	Inductance (μH)	Stored energy (J)
1	1.3	0.65
10	18	9

The energy is ample to damage many electronic components. Semiconductor junctions, for example, can be damaged by energy of the order of microjoules (1 microjoule [μJ] = 10<sup>-6</sup> J).

Note: An energy level of 1 joule (J) is approximately the energy needed to raise an average-sized apple 1m. If you catch an apple dropped from a height of 1m, the impact on your hand represents about 1J of energy.

Note: So far, we have assumed the wiring is straight. Bends in cables increase inductance: the reason why coils of wire are commonly used as 'inductors'.

## 5.4 Surges on cables – some real measurements

This section describes results from measurements using simulated lightning surges and the conclusions that can be drawn from these.

Surge testing is done using standard waveforms. The one shown in the oscilloscope trace reproduced in figure 13, which was used throughout these tests, is the so-called '8/20' waveform since it rises to peak current in 8μs, and falls to half the peak after 20μs.

Note: This waveform definition is not strictly precise – as the waveform is defined mathematically – but is adequate in practice. The plot in figure 13 is a close approximation produced by a real generator.

To achieve the result shown in figure 13, a peak current of slightly more than 1kA was used. For reference, a copper sheet was placed across the surge generator terminals which were 10cm apart. A peak voltage of 5V was developed. Replacing the copper sheet with 10cm of 16 swg (standard wire gauge) wire produced 27V. The rest of the measurements were done using 1m long loops placed across the terminals.

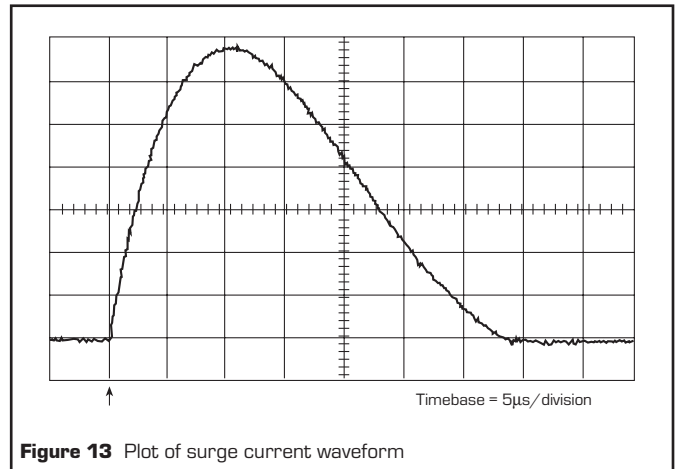

**Figure 13** Plot of surge current waveform

Table 3 shows the voltage across three conductors 1m in length.

**Table 3**

Conductor type	Peak inductive transient voltage (V)
2.5mm <sup>2</sup> cable	250
10mm <sup>2</sup> cable	200
10mm <sup>2</sup> '90A' braid	200
10-way ribbon cable *	170

\*Note: Each of the 10 conductors consists of 7 strands of 0.2mm diameter wire. Total conductor cross section = 2.2mm<sup>2</sup>

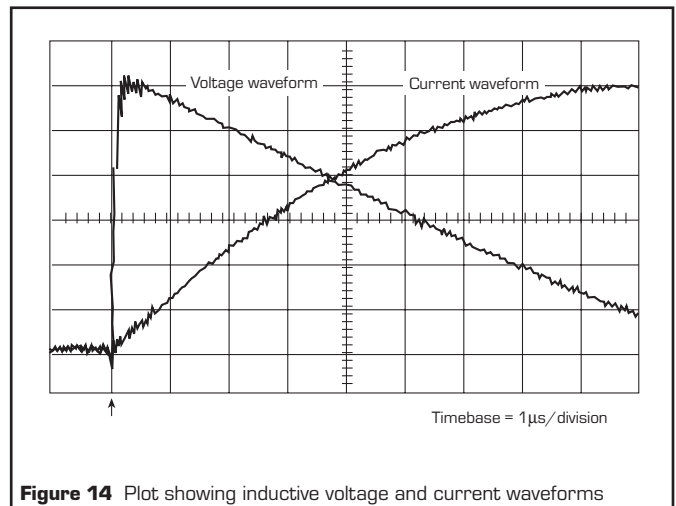

**Figure 14** Plot showing inductive voltage and current waveforms

Figure 14 illustrates the point made earlier about inductive voltage and current by reproducing an oscilloscope plot of the two waveforms.

Table 4 shows the effect of electrically-parallelising 1m lengths of 2.5mm<sup>2</sup> cable, looped between the surge generator terminals.

**Table 4**

Conductor type	Peak surge voltage (V)
Single cable	250
2 cables on similar paths	170
4 cables, similar paths	130
4 cables, differing paths	80

From these results, it can be concluded that two or more cables taking separate paths will provide a lower limiting voltage than a single large diameter cable. Even a small separation between the conductors improves matters considerably. The further apart the cables can be run without making them excessively lengthy, the less magnetic coupling there is between them and the lower the overall inductance.

## 5.5 Inductance – recapitulation

- Where possible, take advantage of available sheet metalwork, e.g. panels or enclosures.
- For circular cross-section conductors, increasing the cable diameter gives a relatively poor improvement for the extra installation difficulty.
- For a given cross-sectional area, flat conductors are better than round ones.
- Running several cables electrically in parallel and physically spaced apart by several centimetres gives a worthwhile improvement.
- A device which has many straight, flat, parallel conducting paths is called a 'metal sheet' or 'panel'!

## 6 SURGE EARTH POSITION

### 6.1 The trouble with a high impedance surge earth ...

Having considered surge earth inductance, we are in a better position to understand the consequences of having too much of it. Figure 15 illustrates an SPD connected between an incoming signal line, shown as a wire pair; and a piece of equipment. The SPD is connected to the equipment earth conductor (typically the protective earth conductor) which, in turn, is ultimately connected to ground. This gives a relatively long path.

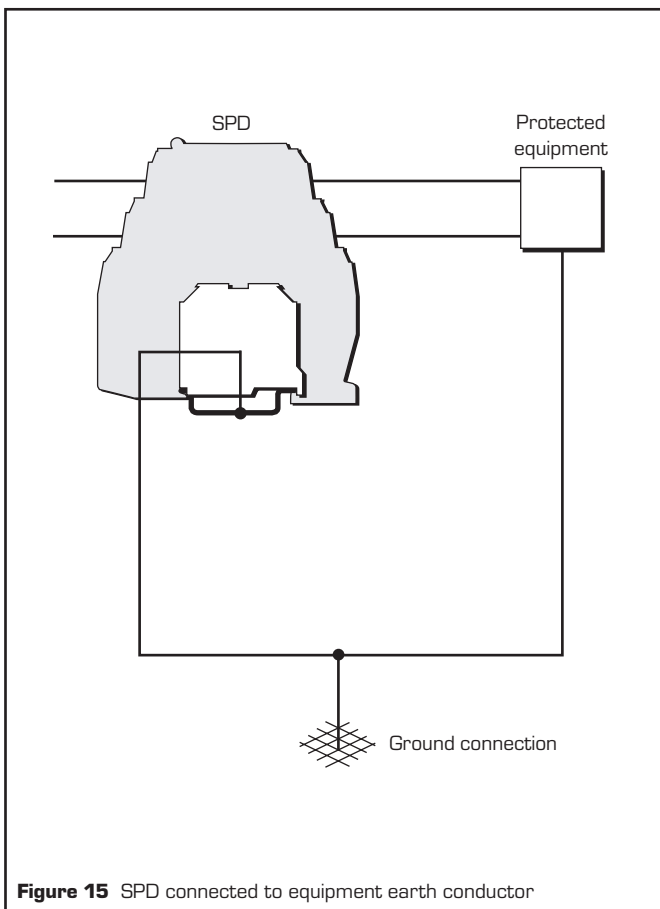

The cables can be represented by their equivalent impedances – inductance in series with resistance – as shown in figure 16.

A common mode surge appearing on the cable indicates the presence of a transient voltage between the cable and the ground connection. The SPD operates and a rapidly increasing current starts to flow down the surge earth. The voltage across the SPD is limited to its normal limiting voltage. However, due to the relatively high impedance of the surge earth, a large voltage appears across it. The equipment sees this voltage plus the SPD limiting voltage – and the transient voltages can be added to the diagram (figure 17) while if there is a breakdown (usually destructive) within the equipment, another current path is generated (figure 18).

Note that current now flows out through the 'protected' or 'safe' end of the SPD. If the current path has a low enough impedance, the equipment and the SPD output components can be damaged.

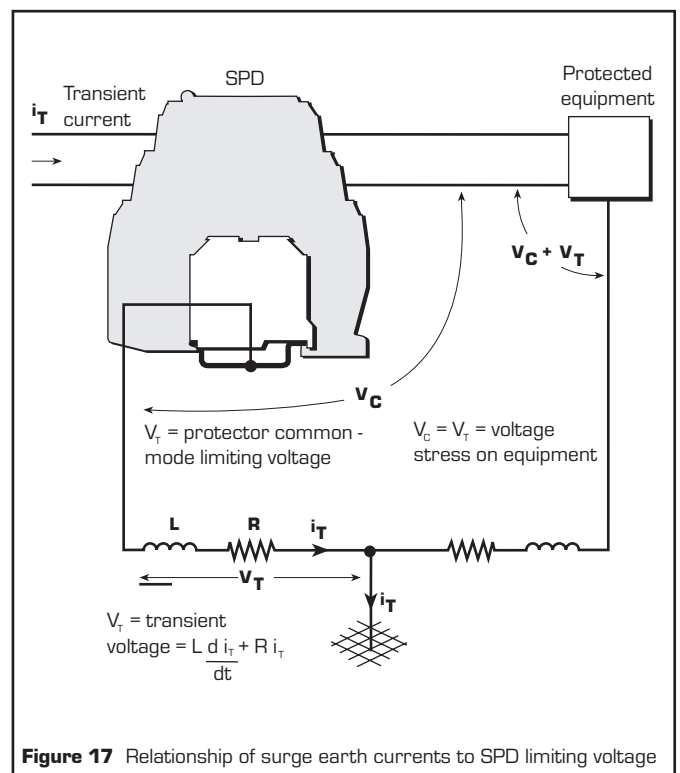
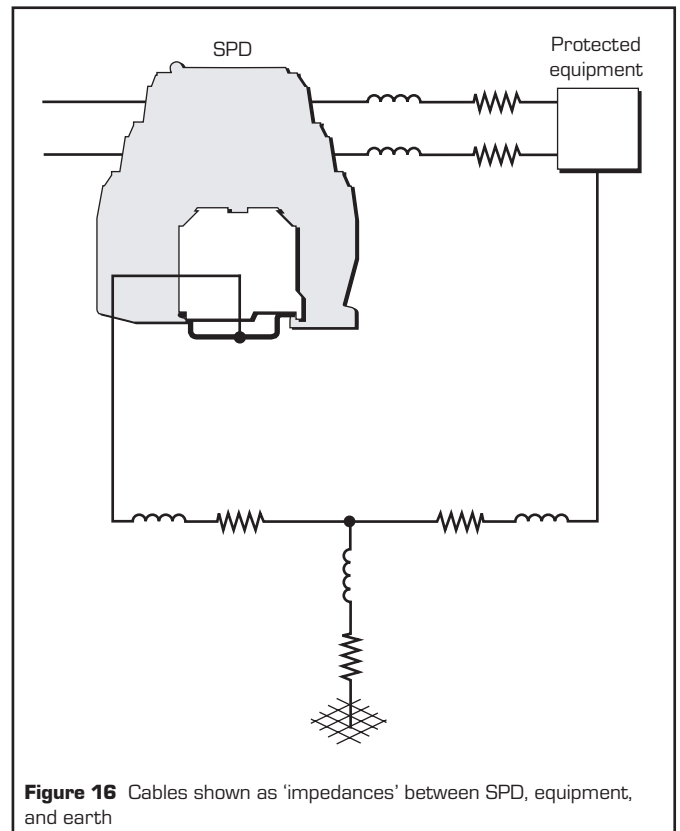

### 6.2 Re-positioning the earth connection to reduce the limiting voltage

The limiting voltage can be lowered by re-positioning the earth connection. Locating the equipment earth (i.e. its zero-volt reference) at the SPD earth point produces the configuration shown in figure 19.

Figure 20 adds the currents and voltages to figure 19. The equipment is now subjected to an inductive voltage transient across the earth cable. There is still a large transient voltage developing between the ground point and the SPD, but this not appear across the equipment which receives only the limiting voltage of the SPD – which is as it should be. In section 7 we will see how, in practice, the SPD can be positioned to satisfy the configuration depicted in figures 19 and 20.

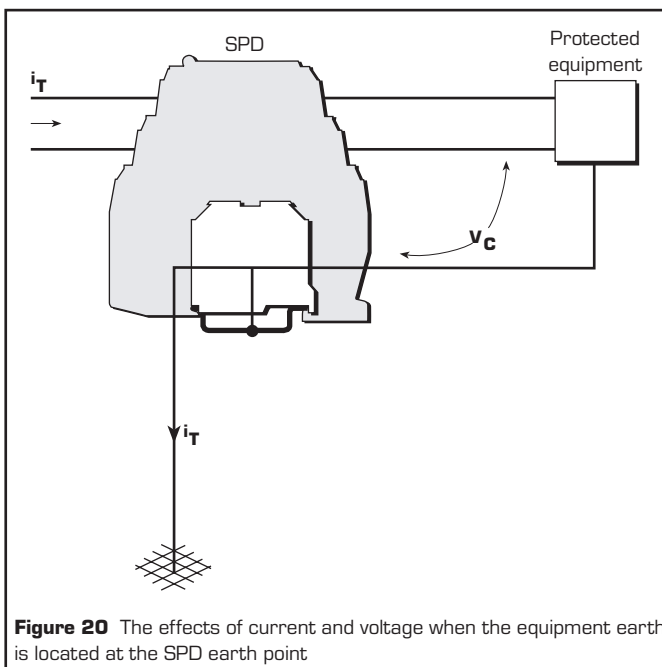
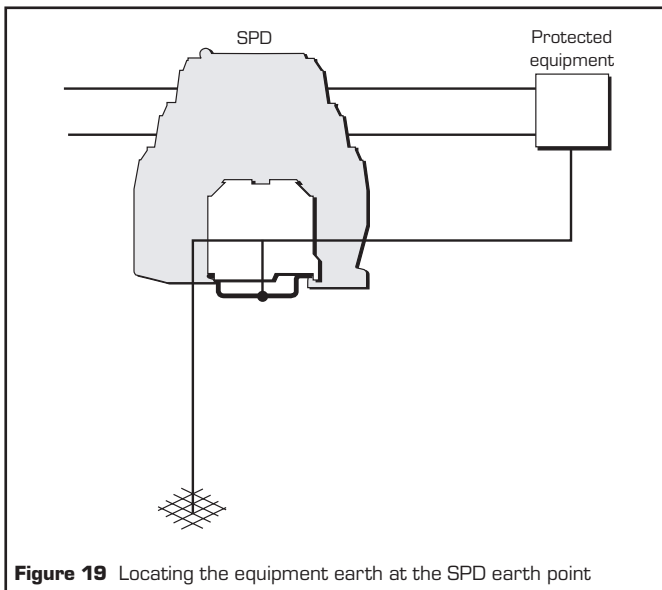
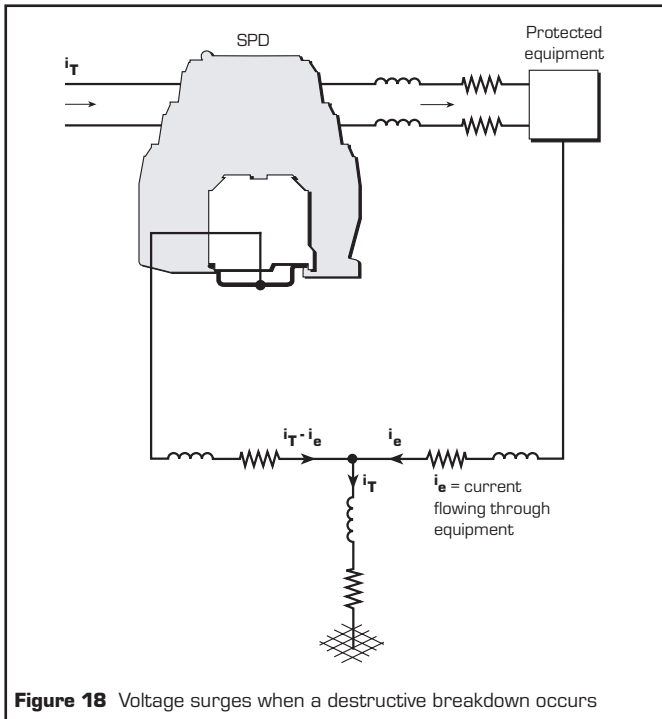

### 6.3 Using a 'surge link' when the earth connection cannot be re-positioned

There are bound to be circumstances in which an SPD and the protected equipment are obliged to be some distance from the common earth point (figure 21). If the SPD and equipment can be located close to each other, the limiting voltage can be reduced by bonding the two with as short a length of cable as possible. This is known as a surge link. Surge current is now shared between the SPD and equipment earths. The inductive transient voltage between them is reduced to that across the surge link.

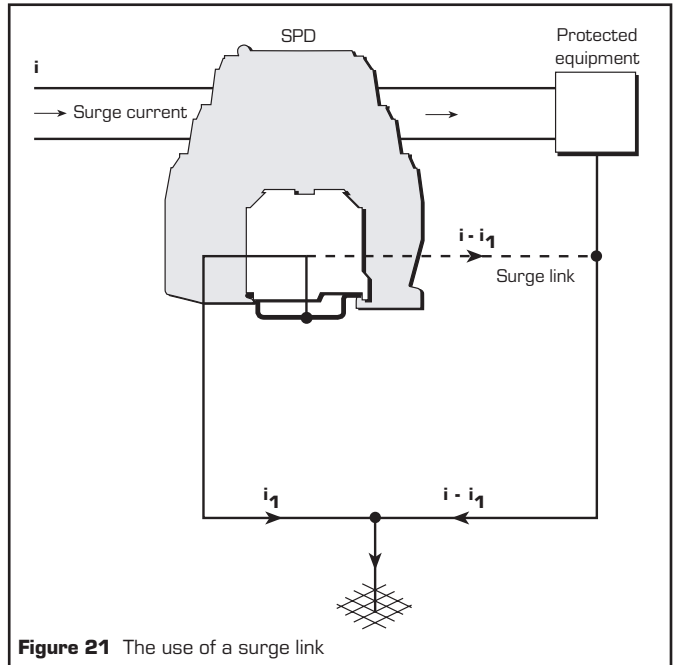

Having emphasized the need to keep cables short to minimise inductance, with a surge link installed as in figure 21, it is apparent that it is an advantage for the equipment earth cable to have a high surge impedance relative to that of the SPD (which can be done by making it from longer coiled wire). Less surge current will then flow through the surge link and the limiting voltage will be lower.

Note: Resistance MUST NOT be added to the equipment earth as this can prejudice safety.

## 7 EARTHING SYSTEM CONFIGURATIONS AND INSTALLATION

### 7.1 Star-point earthing

A typical installation includes a number of items of equipment or devices, each with its own connection. If these are all connected to a common point, from which a cable runs to ground, the result is a star-point earth system (figure 22).

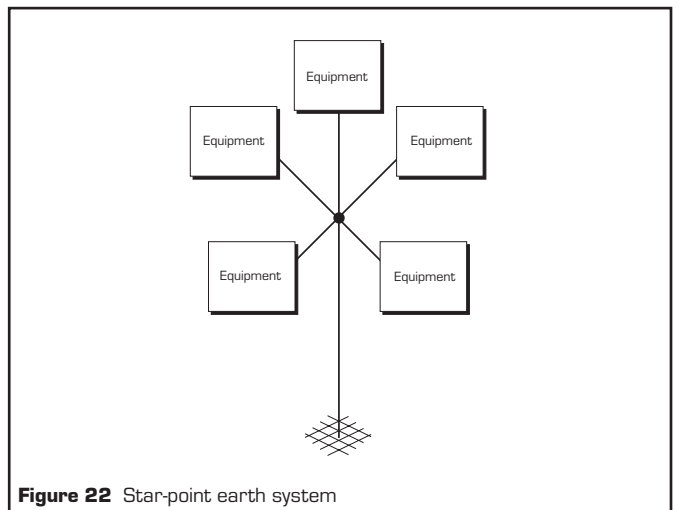

The individual devices are generally also linked by other cables but these have been omitted in figure 22 to avoid cluttering the diagram.

Bearing in mind that the purpose of an earthing system is to keep all equipment within it at the same potential, we should now investigate what happens when current flows through the earth connection of just one device – see figure 23. The current  $i$  develops a voltage  $V$  across the impedance  $Z$  of its earth connection and this potential difference exists between this device and the others. Typically, a much larger voltage will be developed across the common ground connection but this does not affect the potential difference between the devices which can be thought of as moving together in potential.

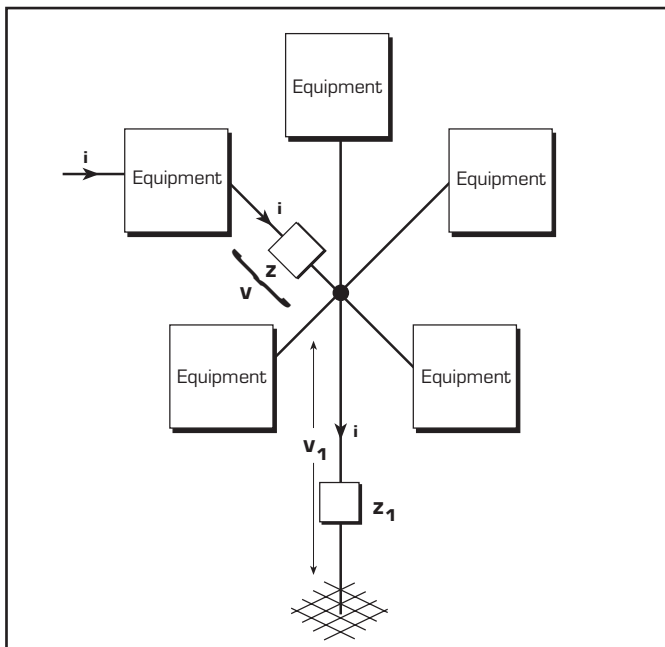

Figure 23 Current flow through one device in a star-point earth system

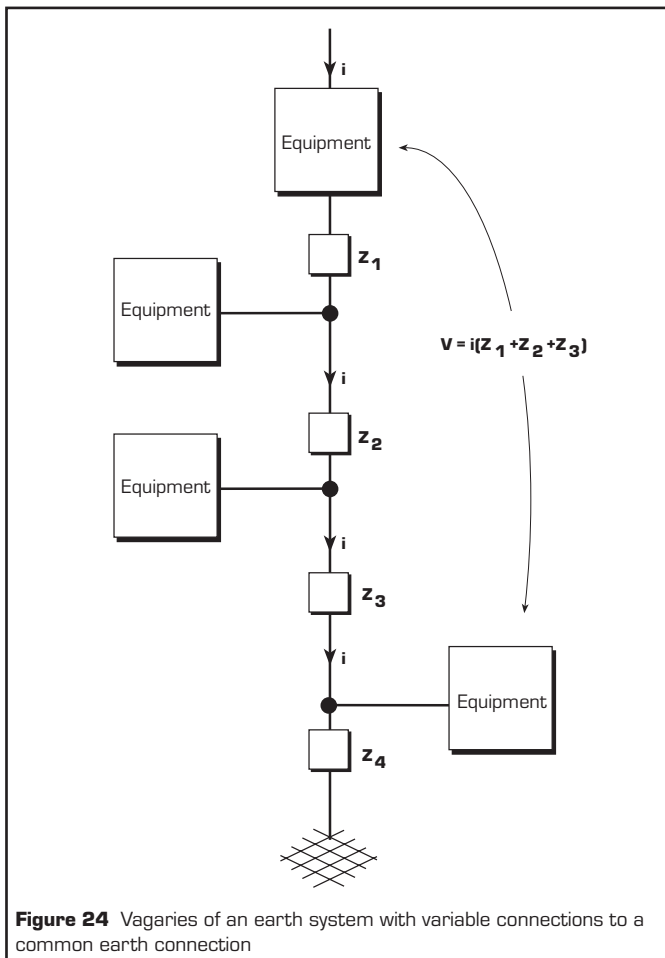

Figure 24 Vagaries of an earth system with variable connections to a common earth connection

The benefit of the star-point system is evident when compared to an earth system in which various devices are connected at various points along a common earth connection (figure 24). This illustrates the 'worst-case' condition in which the current flowing down the earth conductor leaves each device at a different potential.

## 7.2 Implementing a star-point earthing system

### 7.2.1 Basic principles

In a typical installation, there will be a protective earth system such as that provided by the mains protective earth conductor. Ideally, interaction between the SPD earth and the protective earth should be minimised by star-pointing them together. How?

First, find the point on the protective earth system which is electrically closest to ground. In a factory or office, this is likely to be the earth terminal of the main distribution board where connections are made to the incoming electricity supply. This provides the star-point to which all SPDs should be earthed, using connections which are as short and direct as possible. Surge currents can then flow to ground without flowing through the protective earth system within the building. As we have seen, these currents will generate a voltage between the earth terminal and the connection into the ground. The whole earthing system will rise in potential relative to the ground connection but minimal potential differences will be generated between devices within the installation.

Fitting SPDs for various devices at the main earthing terminal does call for all affected signal lines to be run close to this point – this is 'best practice' for surge protection and should be done more often than it actually is.

### 7.2.2 Star-point system installation – summary

- ◆ Locate the point on the protective earth system within the installation which is electrically closest to ground (e.g. the earth terminal on the main distribution board) – this will be the star-point connection between SPD earths and the supply protective earth.
- ◆ Route all signal cables to run as close to this point as possible.
- ◆ Fit SPDs on all signal lines as close to the star-point as possible.
- ◆ Connect the SPD earths to the star-point using connections which are as short and direct as possible.

### 7.2.3 Practical connections

If possible, make use of system metalwork, such as may be present at the main distribution board and mount the SPDs on metal panels to minimise the inductance of their earth connections, taking care that any paint or grease is first removed.

## 7.3 Surge earths and protective earths

Having introduced connections between surge protection devices and the mains supply system of the particular building, it is advisable to review what these are for.

### 7.3.1 Surge protection earths

The purpose of the surge protection earth is to carry transient currents to ground by as direct and low-impedance a path as possible – to minimise common-mode limiting voltage and to provide the best equipment protection. For this we recommend the use of 2.5mm<sup>2</sup> minimum cross-section cable where necessary (i.e. where metal panels cannot be used).

### 7.3.2 Mains protective earths

The purpose of a mains protective earth conductor is to carry supply frequency fault currents for long enough to allow current-limiting devices such as fuses and circuit-breakers to operate. The size of this conductor is determined by its ability to carry prospective electricity supply fault currents. The 'prospective current' is the current which the circuit can deliver into a short-circuit fault.

### 7.3.3 Other aspects

If, for any reason, a conductor is used for both purposes, it MUST, at all costs, be capable of carrying the prospective fault current and sized accordingly – remember, SAFETY FIRST!

In some circumstances, the surge and protective earth conductors are in parallel. Provided there is always an adequate protective earth conductor and good surge earthing practice is followed, it does not matter if surge and fault currents are shared between the two paths.

To make sure the correct size and type of mains protective earth conductors are used, consult the appropriate regulations. In the UK, this is the IEE Wiring Regulations (BS7671:1992: IEE Wiring Regulations, 16th edition).

### 7.4 Surge protection for external connections

Manufacturers of surge protection devices (including Telematic) recommend fitting SPDs to each cable which enters an installation from outside the building – why? Is this simply a ploy to sell more products?

The answer is NO, for two reasons:-

- a) Each cable provides an opportunity for surges to enter the building.
- b) Failure to protect all cables may allow a surge on one to couple to another.

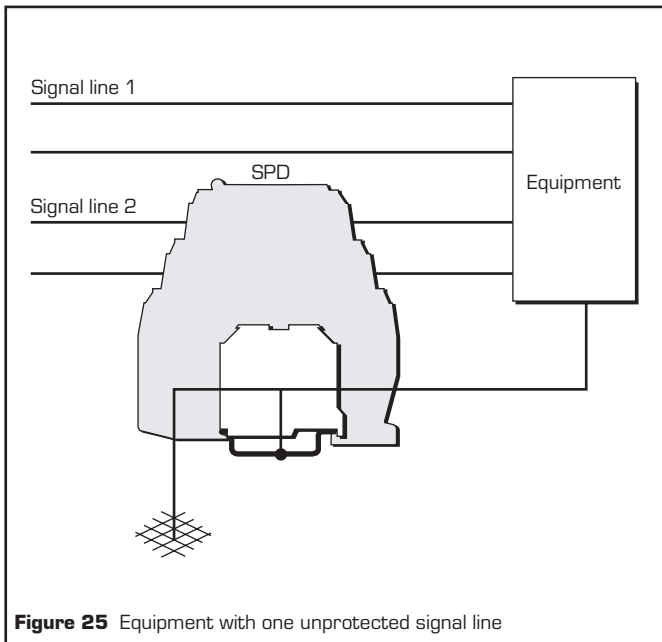

Figure 25 Equipment with one unprotected signal line

#### 7.4.1 Surges entering a building

To illustrate the first point a), consider a device with two cables, both of which come from points remote from the installation and only one of which is fitted with an SPD (figure 25). If, during a thunderstorm, there is a lightning strike to ground near the remote end of the unprotected cable, the device will suffer from a surge on the unprotected line. Breakdown (probably destructive) occurs and current flows to ground, either through the device or through its 'protected' port and the output side of the SPD. In the latter case, both the device and the SPD may be damaged (figure 26).

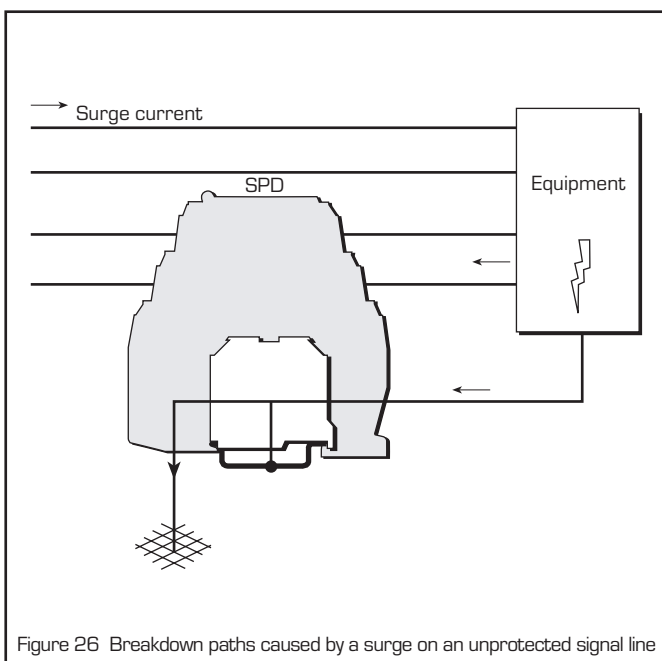

Figure 26 Breakdown paths caused by a surge on an unprotected signal line

#### 7.4.2 Surges coupling from one cable to another

For surge coupling, consider the simple system shown by figure 27 which depicts a signal cable and an item of mains-powered equipment.

During a surge, the SPD on the signal line operates correctly and transient current flows to ground through the earth conductor. However, the inductive voltage across the earth conductor appears between the other mains supply conductors (figure 28). The neutral-earth voltage depends on the distance to the bond between them. If the SPD is at the main earth terminal of the distribution board, where the neutral-earth bond is situated, there will be little or no neutral earth transient and the inductive voltage will appear between the 'live' and the other two conductors. An SPD on the mains supply (figure 29) will limit this surge to a safe level.

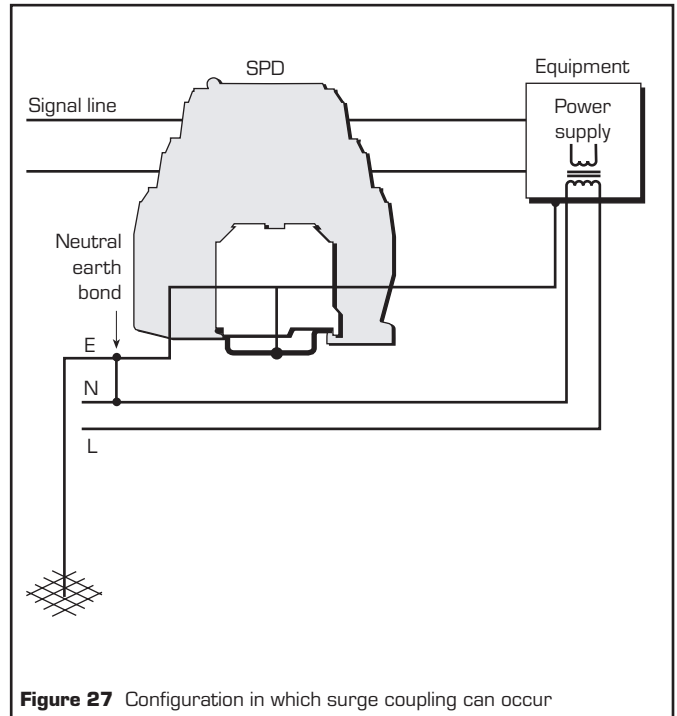

Figure 27 Configuration in which surge coupling can occur

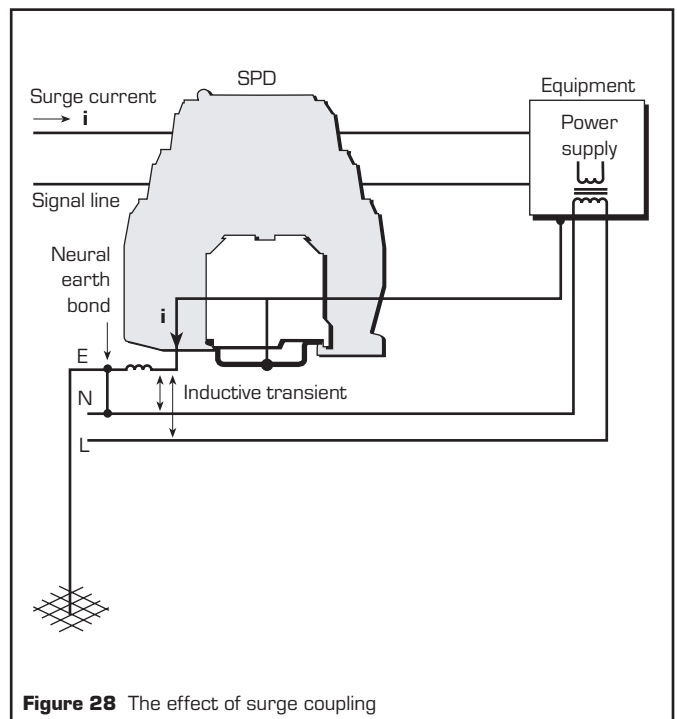
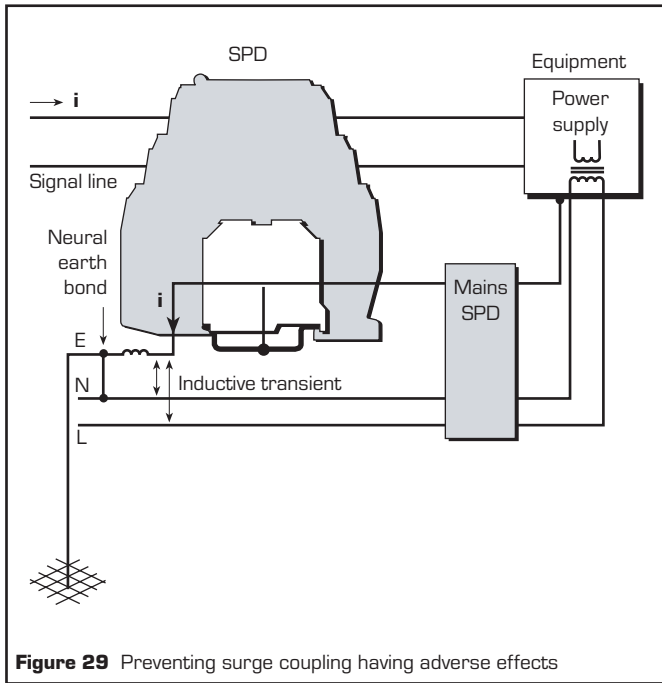
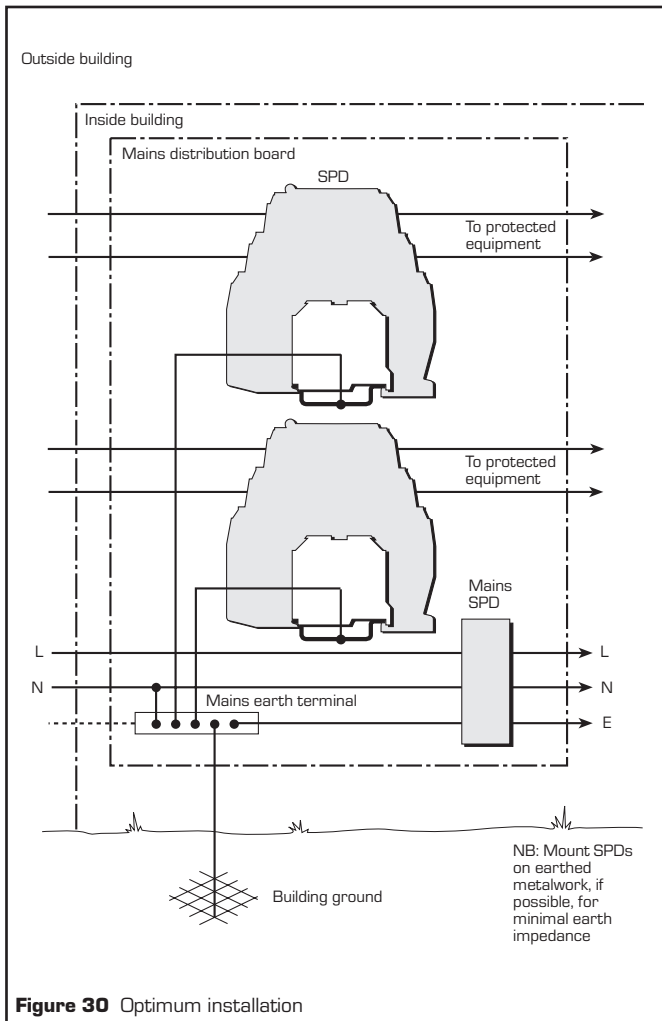

Figure 28 The effect of surge coupling



**Figure 29** Preventing surge coupling having adverse effects

Figure 31 illustrates an optimum installation in a slightly more practical configuration.



**Figure 30** Optimum installation

## 7.5 Cable layout problems associated with cables entering a building at separate points

In practice, signal cables frequently enter buildings at points remote from the main distribution board earth terminal which is the earth reference point for earthed equipment in the building. What then? SPDs are fitted on both the signal line and the mains supply (as described in section 7.4) to provide protection to the equipment served by the cable. However, there is

a very long cable path back to the earth terminal. How can we mitigate the effects of this? There are several possibilities:-

- Equipment relatively isolated: no signal cable links to other equipment in the building; earth cable not shared with other equipment – see section 7.5.1.
- No internal signal cables: but shared earth path (more likely) – see section 7.5.2.
- Internal cables: earth path not shared – see section 7.5.3.
- Internal cables: with shared earth paths – section 7.5.4

### 7.5.1 Equipment relatively isolated

A typical example of a device which is 'relatively' isolated is a telephone or fax machine (figure 31). A lightning surge lifts the potential of the cable relative to the local ground. The SPD operates and surge current passes down the surge earth protector. An inductive transient develops across the earth conductor. However, the fact that the equipment is isolated, protected and does not share surge current with other equipment, means 'all's well'.

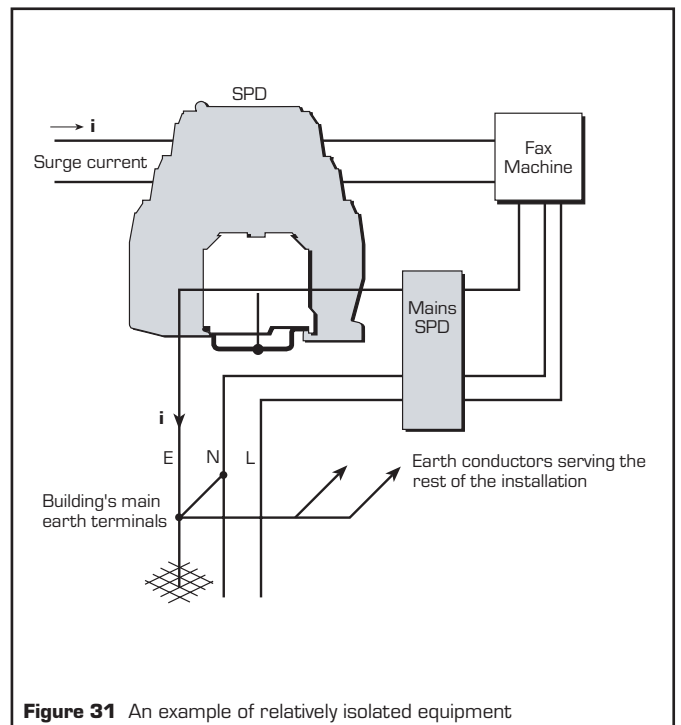

**Figure 31** An example of relatively isolated equipment

### 7.5.2 No internal signal cables (with shared earth path)

Again, the equipment could be a fax machine (figure 32) but one which this time shares an earth as part of the mains earth system (e.g. a ring main). Note that the quality of surge protection has improved. The fax machine will survive. Had it not been protected, the surge current would have damaged the fax machine and a mains transient would still have occurred.

### 7.5.3 Internal cables (no shared earth path)

An example of an internal cable with no shared earth path, figure 33, could be a modem serving a personal computer (PC). At least some of the surge voltage developed across the earth cable may appear on the link to the PC, so there is still the possibility of damage to the PC. If the surge earth path cannot be shortened in practice, the modem with its SPD should be moved closer to the PC and all earthed together.

### 7.5.4 Internal cables (shared earth paths)

This combines the cases discussed in 7.5.2 and 7.5.3. Transients on internal cables and the mains supply are possible.

### 7.5.5 Summary

There is no easy way of handling the situation when cables enter a building at points remote from the main earth terminal. If possible, the cables should be re-routed. If not, SPDs should be fitted to the devices terminating the cables. Where this equipment is linked electrically to vulnerable or strategically-important items of equipment elsewhere in the system, surge protection can be considered for these. Poor cable layout should not be used as an excuse for omitting surge protection which can still reduce significantly the risk and/or severity of damage.

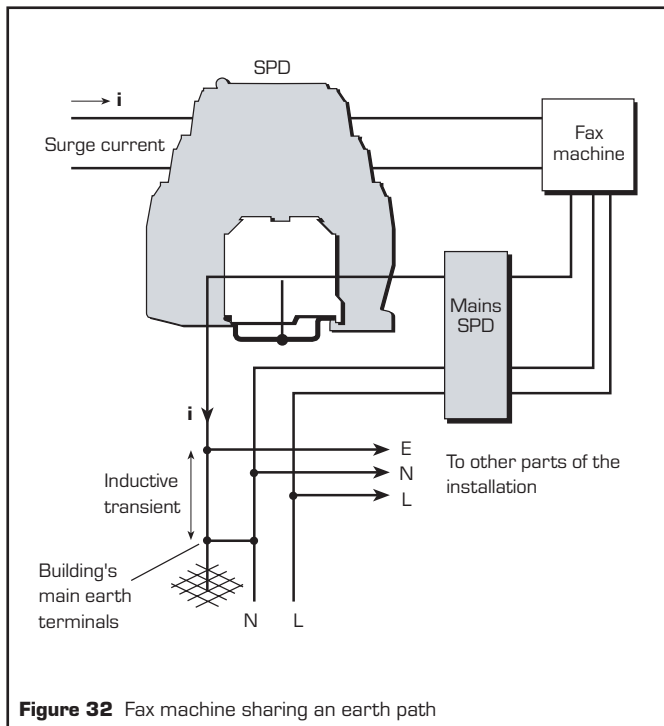

**Figure 32** Fax machine sharing an earth path

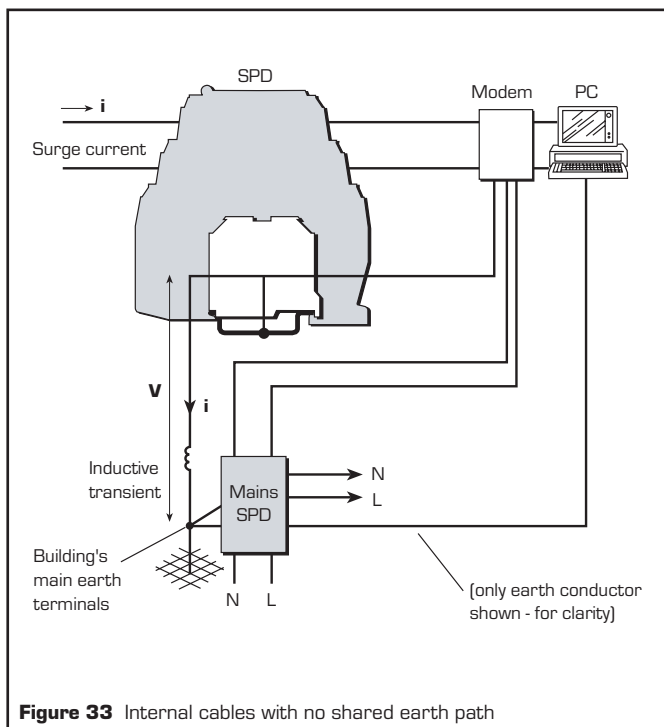

**Figure 33** Internal cables with no shared earth path

## 7.6 Ground electrodes, ground impedance and surges

### 7.6.1 General

As we have seen earlier; lightning discharges to ground set up large transient voltages, with respect to local ground, on incoming cables. So far, in dealing with surge protection, we have assumed a connection to ground without considering the detailed implications. There are questions worth asking.

Why have a connection to ground at all? Why not just insulate the system and stop surge currents flowing at all, rather than bothering with low inductance star-point earths and the like?

The answers stem from the huge voltages and currents involved in lightning discharges. The voltage is so great that stroke current can be regarded as coming from a constant current generator: In other words, the current will flow. Our only hope is to control its path. To protect the structure of a building we might try to make it emulate an aircraft by enclosing it in a metal skin and placing it on insulating stilts (back to our ideal 'metal box?'). But, apart from amusing us, nothing would be gained for two reasons:-

- The aircraft 'works' because it has absolutely no connection to ground (apart from the atmosphere), unlike a building where, for example, there is often a connection to ground through the mains supply.
- It would be hideously expensive.

Having accepted that our building is irredeemably anchored to the ground, do we need to bother about ground impedance? Suppose we are responsible for a remote monitoring outstation. There is one incoming cable from a transducer and a radio telemetry transmitter which is solar powered with no mains supply connection. This is an approximation to the isolated telephone or fax machine considered in section 7.5.1 and a ground connection may not be necessary. However, there are two reasons why sinking a ground rod at the outstation may still be worthwhile.

- If the transducer cable is long, there may be sufficient voltage caused by a ground potential surge to cause flashover from the cable, through the telemetry equipment, to the fabric of the building.
- There is also a risk, albeit slight, that someone in the outstation, with feet at local ground potential, might receive a shock from touching the equipment during a storm.

These possibilities can be avoided or alleviated by sinking a ground rod at the outstation and fitting an SPD, as shown in figure 34, with the SPD earth as the star-point.

Provided star-point earthing is used, ground impedance is NOT critical for surge protection of electronic equipment.

Note : What is generally measured, and referred to, is ground resistance. In this publication, ground impedance is preferred as a reminder that there will still be some inductance in series with the resistance.

There is little point struggling to achieve, say, a  $1\Omega$  ground impedance (the type of figure associated with large plant such as power stations). That is why relatively little tends to be said about ground impedance when surge protection of electronic equipment is considered. The advantage of a relatively low ground impedance is illustrated by figure 35. The equipment shown has two signal cables, each protected, with a further SPD on the mains electricity supply. The equipment is therefore well-protected and will not be damaged. However, surge current travelling down one signal cable passes through the ground impedance, developing a voltage across it. This voltage will be 'seen' at the remote end of the other signal cable. The higher the ground impedance, the more the surge can be viewed as being 'passed on'. See Appendix A for a simple model illustrating the effect of ground electrode resistance.

### 7.6.2 Recapitulation

- ◆ For protecting a single installation, a very low ground impedance is not necessary.
- ◆ A multi-installation as a whole will benefit from low ground impedance.
- ◆ There is no magic figure for an acceptable level of ground impedance.
- ◆ The ground impedance achieved will in many cases be determined by the characteristics of the ground and available time and funds.

See Appendix C for further reading on this subject.

## 7.7 Connection to the structural lightning protection system

As may be apparent from section 7.6, structural lightning protection is provided on the assumptions that:-

- The building WILL be struck.
- When it is, the consequent damage from the large currents involved can be considerable.

Its purpose is to define a path for lightning current to flow to ground as directly as possible. The voltages developed between lightning conductors and the electrical system, if isolated from each other, can be enormous enough to cause destructive flashover. For instance,  $50\text{kA}$  flowing through  $20\Omega$  develops 1 million volts! It is therefore safer to bond the two systems. The preferred method is by a cable from the main earth terminal (the system star-point) by as direct a route as possible to a point on the down conductor system close to the soil or below, such as at the earth mat itself. See figure 36.

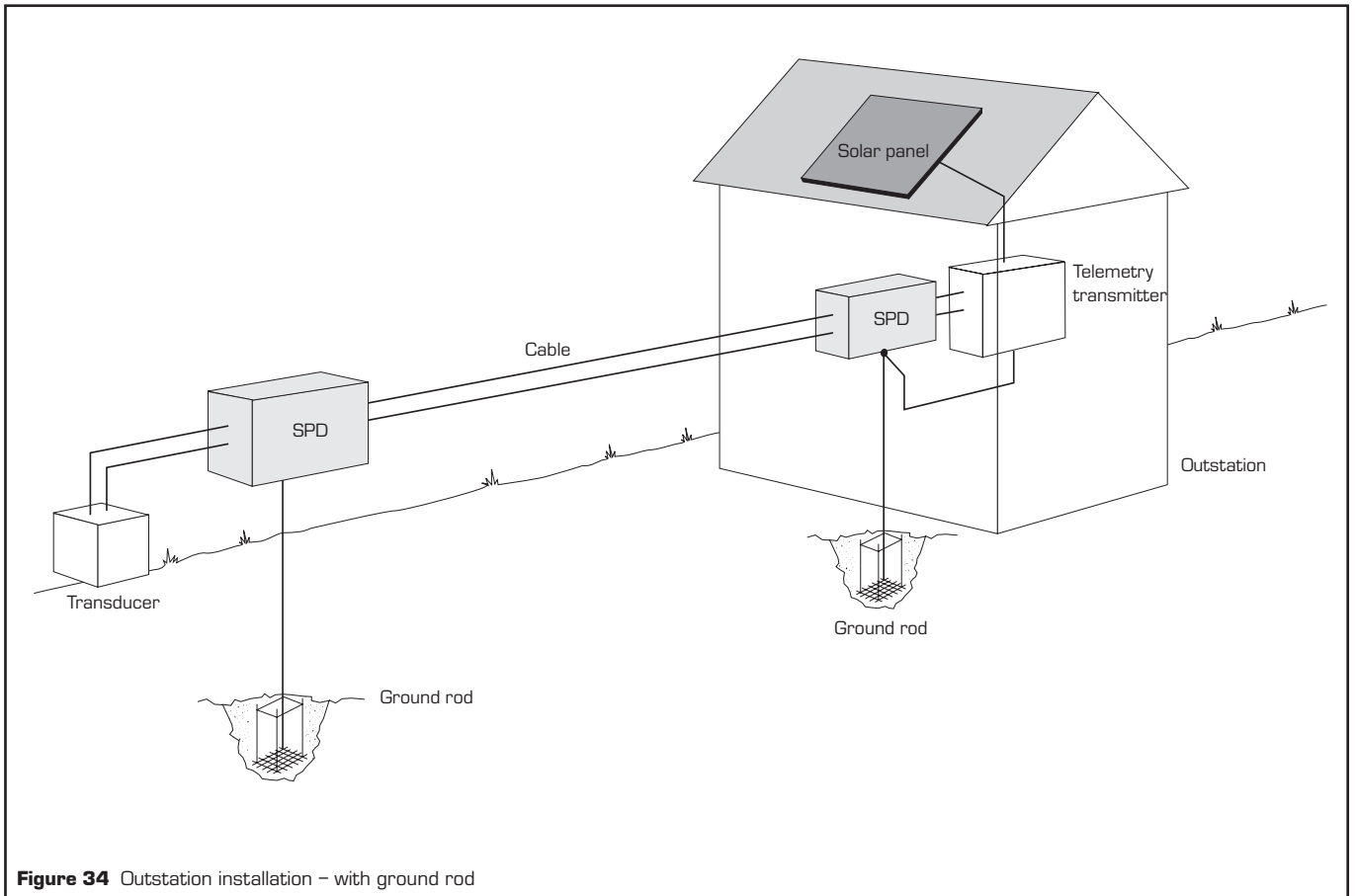

**Figure 34** Outstation installation - with ground rod

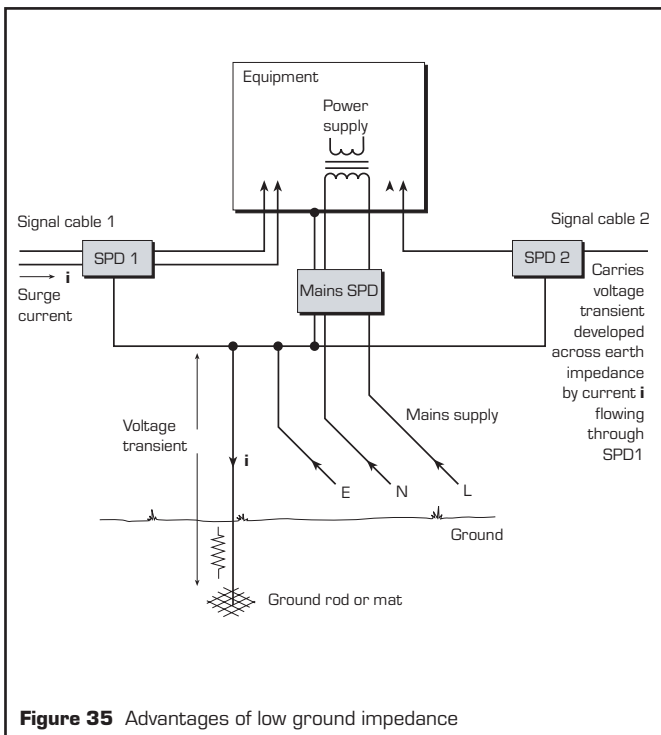
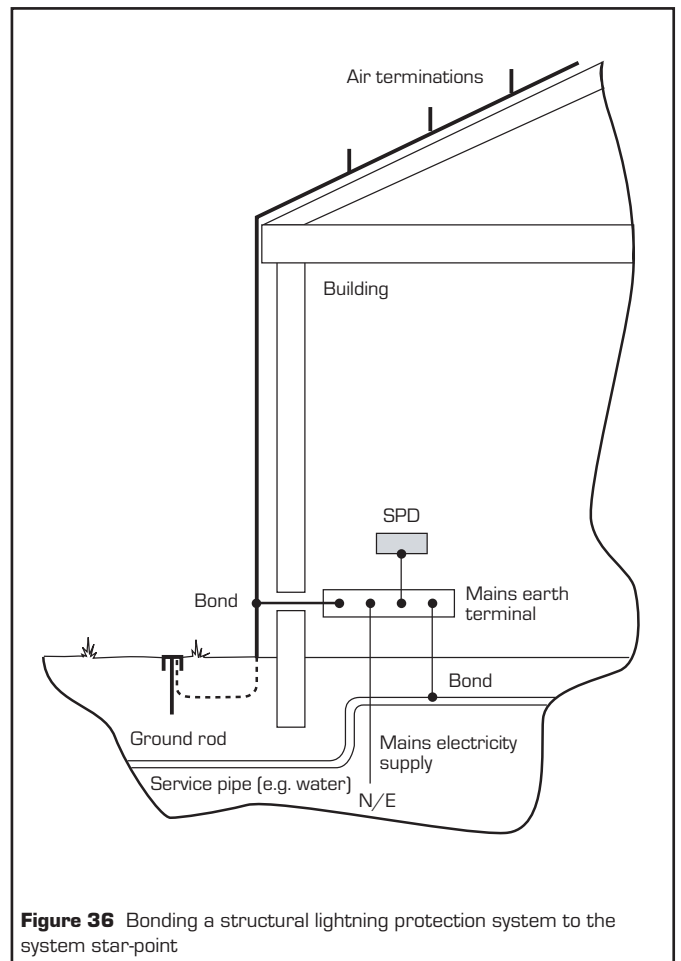

**Figure 35** Advantages of low ground impedance

This is no more than a brief summary and is intended to raise awareness. To avoid straying beyond the scope of this publication, we recommend consulting an appropriate standard which, in the UK, is BS6651: 1999 Protection of Structures Against Lightning.

### 7.8 The other end of the cable

If you are responsible for protecting equipment at both ends of a cable (e.g. an installation involving more than one building or a telemetry link with a remote sensor), then treat both ends of the link in the same way. Equipment at each end is connected by the cable to the local ground at the other end (in fact, SPDs make sure this is the case). Without protection, a lightning surge can cause a large potential difference to form between these ground connections.



**Figure 36** Bonding a structural lightning protection system to the system star-point

Fit an SPD at each end. Surge current can then flow harmlessly between the two ground points through the SPDs, rather than destructively through the equipment (figure 37). As always, keep the surge earth cables short or, where necessary, fit a surge link.

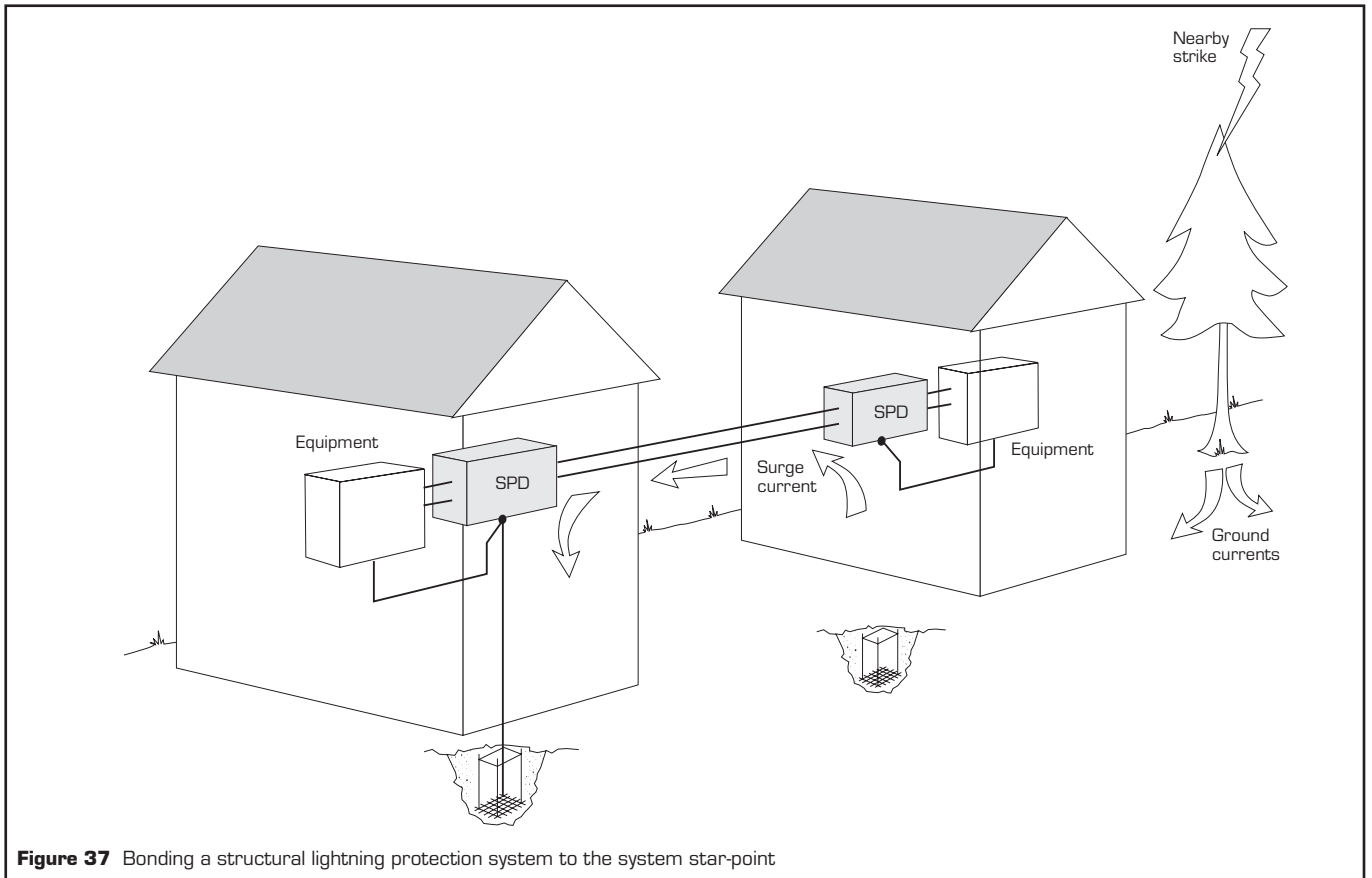
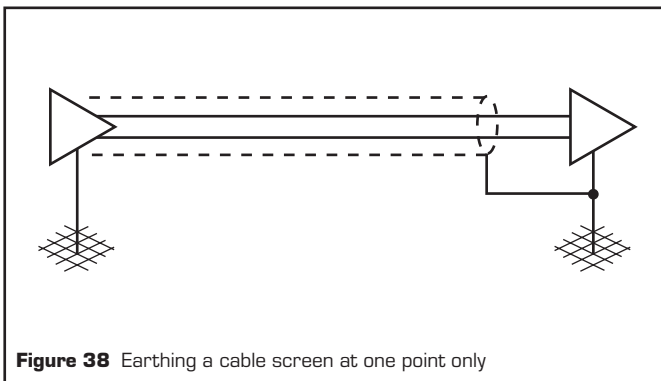

**Figure 37** Bonding a structural lightning protection system to the system star-point

## 8 MISCELLANEOUS TOPICS

### 8.1 Shielded cables and earth loops

To prevent unwanted pickup of stray electric fields, cables carrying low-frequency low-level signals often use an overall screen. Single-point earthing is usually favoured to break hum loops. In situations where SPDs are not necessary, the simplest method of achieving a single-point signal earth is simply to connect the screen at one end of the cable only (figure 38). However, where SPDs are fitted, more than one earth/ground connection is a necessity. Is there a conflict?

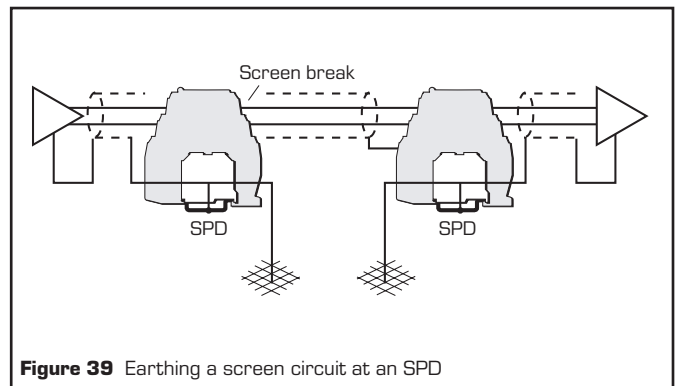

**Figure 38** Earthing a cable screen at one point only

Generally, the answer is no. The SPD only provides a low impedance path to ground when it actually operates to protect the system (during which time no one is likely to be upset by a hum loop!). The rest of the time, its capacitive impedance is high enough to break a hum loop.

Note: Most SPDs have a line-to-ground capacitance of a few nanofarads at the most, and, in some cases, only tens of picofarads – at 50Hz mains frequency, a 10nF capacitor has a reactance of more than 300kΩ.

When SPDs are included in the system it is usually physically convenient to provide the break in the screen circuit at one of the SPDs – see figure 39. This diagram shows the ideal earth positions for lightning protection, but often the real situation will be more like that shown in figure 40, in which case the need for the SPDs to be mounted as close as possible to the transmitter and receiver will be appreciated.



**Figure 39** Earthing a screen circuit at an SPD

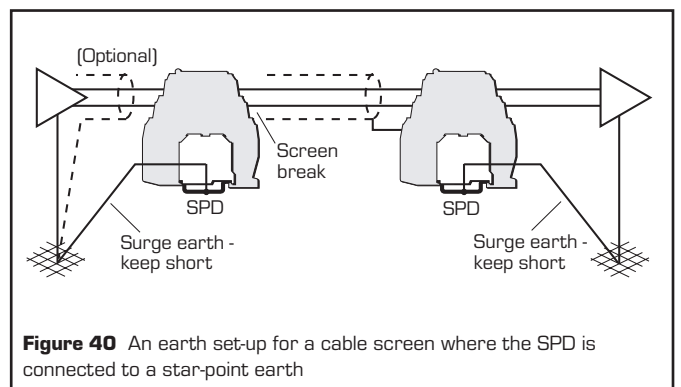

**Figure 40** An earth set-up for a cable screen where the SPD is connected to a star-point earth

Note: In figure 40, if the screen shown as optional at the left-hand side of the diagram has a total conductor cross-section of 2.5mm<sup>2</sup> or more, it can be used as the surge earth.

Another situation likely to be encountered is illustrated by figure 41. In this case, there is an appreciable length of cable connecting the SPD and the equipment to the star-point earth with the possibility of large transient voltages. In this case, the cable screen can serve as a surge link to reduce the transient. This, however, creates a loop which can cause problems, depending upon the system. Minimising the loop area by running the surge earth cable close to the screen may be helpful.

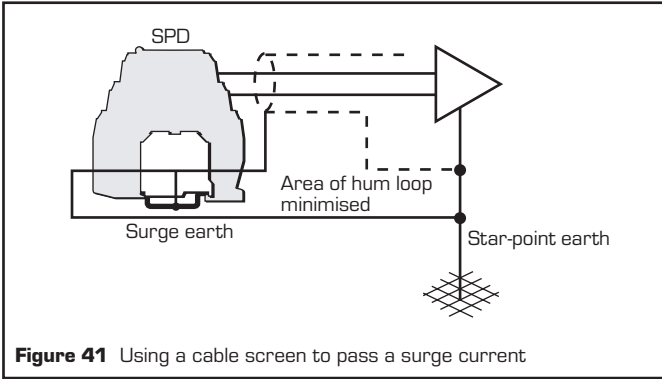

**Figure 41** Using a cable screen to pass a surge current

Note that the cable screen break should be made with the screen clearly separated from metalwork, such as the SPD, which may be at a different potential. A 10mm separation, especially if the screen is well insulated, should normally be adequate. Alternatively, it may be an advantage for the surge current to pass down the screen, with its higher current capacity, rather than the inner conductors alone. This can be done by connecting the screen to one side of an SPD as shown in figure 42. The SPD maintains a break in any hum loop as described earlier.

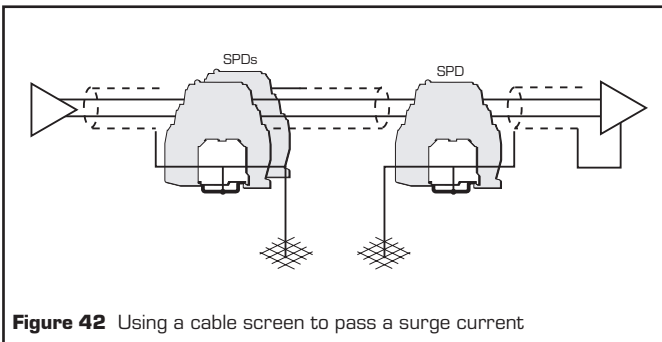

**Figure 42** Using a cable screen to pass a surge current

For further reading on this subject, see Appendix C.

## 8.2 Protecting baseband transmission systems using co-axial cable

The term 'baseband' refers to relatively low-frequency signals (up to several tens of MHz) as distinct from signals transmitted on higher frequency carriers (e.g. cable TV).

Network and video SPDs (ZoneBarrier and VP Series) are available for this purpose. They are available in versions designed to cope with the differing requirements of computer networks and video circuits respectively. Both types are effective in breaking hum loops, due to their very high screen to earth impedance. The ZoneBarrier, in addition, has a simple earthing option by which the co-axial cable screen can be either directly earthed or isolated.

Earthing for protection follows the same general rules set out elsewhere in this publication.

## 8.3 Protecting high-frequency co-axial cable systems (e.g. antenna feeds and CATV)

For frequencies of tens of megahertz (MHz) and above, an SPD must have very low capacitance. Transmitting applications also require high voltage operation. Wideband co-axial SPDs, such as the Telematic CA Series, based on gas discharge tube protection elements in special housings, are designed for the purpose. Insert an SPD close to vulnerable equipment where there is the best available ground point. The installation rules for these are exactly the same as for all other SPDs. The only differences are the very low capacitance of these devices and their symmetry (i.e. they can be mounted either way round). See figure 43 for a typical installation.

The co-axial cable shield should be bonded to the base of the antenna tower, as shown, to avoid direct strike current flowing down the feeder into the building. If the tower is tall, the cable should be bonded to the tower every 10m or so to avoid flashover between the tower and the cable. Having more than one earth connection is not normally a problem in this type of system

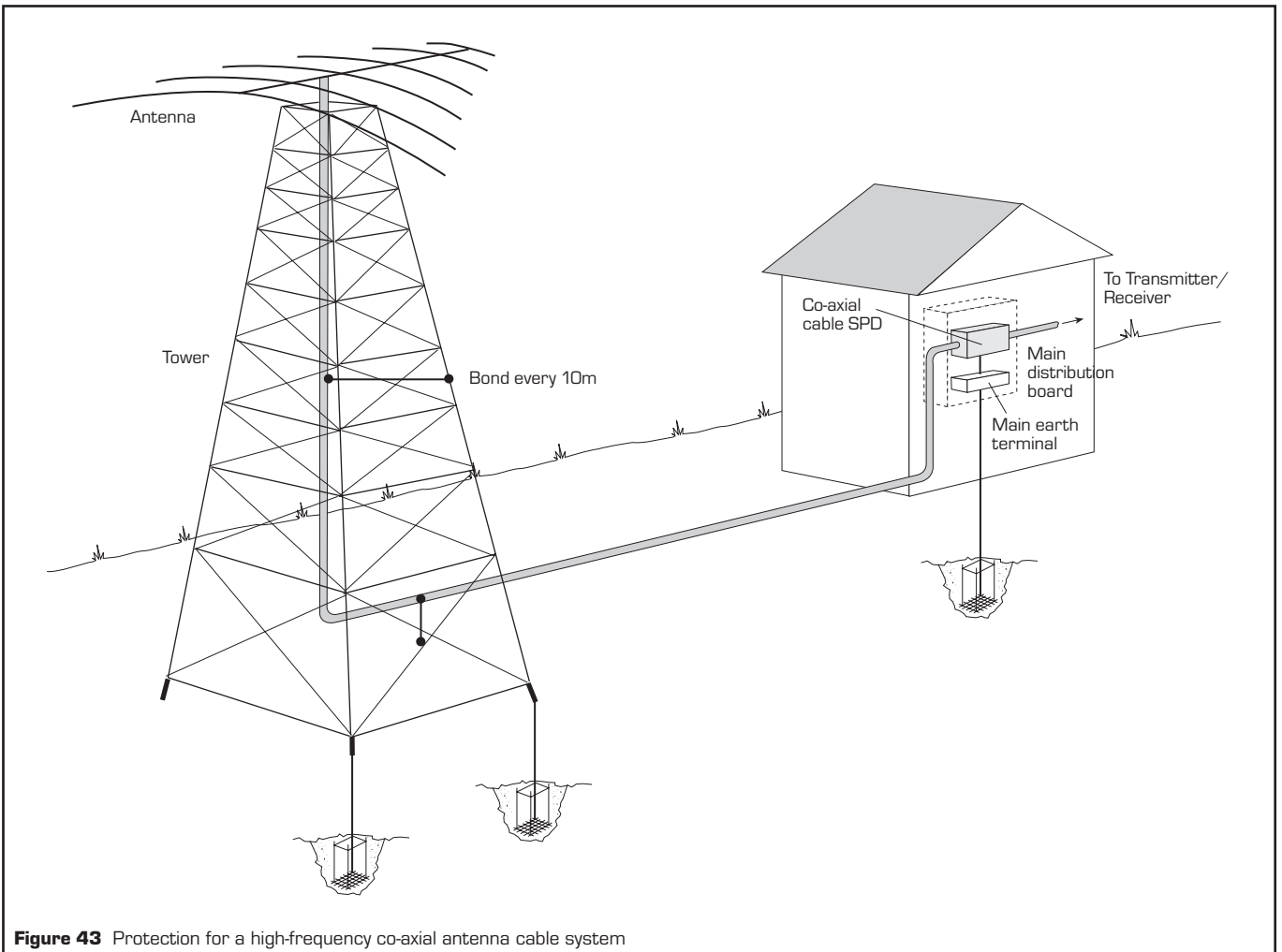

**Figure 43** Protection for a high-frequency co-axial antenna cable system

as the signal frequencies are well removed from mains hum-loop frequency and, at the signal frequency, the cable provides effective screening.

### 8.4 Protecting the mains supply

Transients can be introduced into a system by the mains supply (as with any other cable) and, as we saw earlier, can be caused when surge currents pass down signal lines and into the mains earth conductor. In general, mains transients are less damaging than at first sight one might expect, because one side of the supply (earth/neutral) is used to define the earth (i.e. zero volt reference) for an installation, which therefore sees only the difference or transverse mode surges. These, however, do commonly cause malfunctions.

The mains supply is also likely to carry disturbances within or close to a site, caused by the switching of heavy current devices such as motors.

The optimum protection scheme is a combined one deploying heavy duty transient suppression at the distribution board and progressively lighter duty transient suppression down to individual devices which, in the case of Telematic devices, also incorporate radio frequency filtering.

Figure 44 illustrates, by way of an example, a combined protection system for a modern office based on the use of various Telematic SPDs. This does not of course provide a universal solution. Telematic staff are fully qualified to recommend solutions for individual situations.

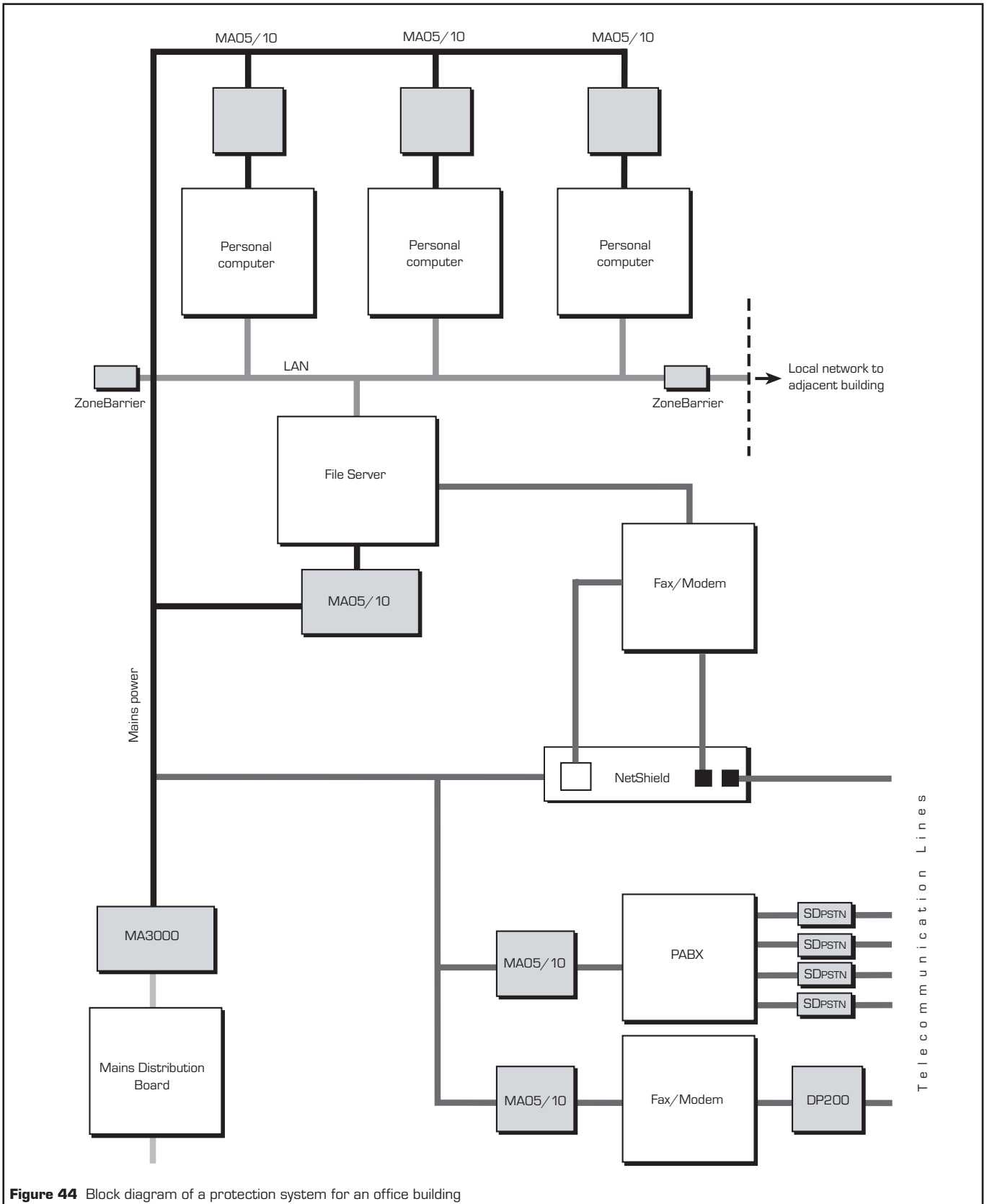

**Figure 44** Block diagram of a protection system for an office building

## 8.5 Surge earths and telecommunications functional earths

Telecommunications practice has developed along somewhat independent lines in different countries. This section applies to UK practice only.

BS6701 is the source document on this subject. Section 6.10 of that publication differentiates between protective earthing (which should be in accordance with the IEE Wiring Regulations) and functional earthing. The use of a functional earth includes 'over-voltage surge suppression', in other words what we have so far called a 'surge earth' is a 'functional earth' in telecommunications parlance. The functional earth (FE) should not be used as a protective earth (PE).

According to BS6701, the functional earth conductor should only be connected to earth either 'at the consumer's main earthing terminal', i.e., our star-point earth, or at a buried ground electrode system. In the latter case, the ground electrode should be bonded to the main earth terminal.

So far there is no conflict between the Standard and this publication. Where some conflict may occur is with the statement; 'Connections between the PE and the FE should be avoided other than the connection at earth'.

In principle, this is exactly in line with our recommendations to fit SPDs at the star-point. However, when this is simply not practical, the requirement for lightning protection may dictate the use of a surge link between the SPD and the equipment. The Standard calls for the functional earth conductor sheath to be cream-coloured and to 'be continuously embossed with the words "Telecomms Functional Earth"'. As this publication stresses, the best protection is provided by a direct metalwork connection at the star-point, without the use of a cable. We do not think this conflicts with the Standard – particularly if the SPD earth connection at the star-point carries a 'permanent label or tag ... with the words "Telecomms Earth Do Not Remove"', as is described in section 6.10.3.3 of the Standard.

Note: Flow of electrons is independent of the colour of the cable insulation!

For further reading, see Appendix C.

## 8.6 Integrated earthing for process systems

### 8.6.1 Introduction

The earthing arrangement for a single SPD and equipment is logical and easy to apply. However, the earthing arrangements for a process system can become daunting when faced with the need to consider all the required

'separate earths' for noise rejection, intrinsic safety (see also section 8.7) and electrical safety. This section suggests a practical solution, well-proven on many industrial plants, which can be applied to most process plant design, either at the pre-construction stage (engineering) or, in some cases, during plant modifications and updates.

### 8.6.2 Preferred earthing 'philosophy' for control systems

For an SPD to provide optimum protection, there needs to be a coherent earthing philosophy. Figure 45 illustrates the philosophy.

Surge currents, whether caused by direct strikes or by changes in local earth potential, need a low impedance path to earth. Such currents entering the marshalling cabinet through the instrument cabling are diverted to earth by the SPD and its own earth busbar from which current should flow to the system earth without flowing through any other earth connection. All other earths should be connected to the SPD earth busbar at one point only.

The instrumentation earth should be isolated from the electrical earth and cabinet. Leakage current from the electrical earth will cause a noise voltage to be added to the SPD busbar potential. However, since the instrumentation earth is referenced to the SPD busbar and not the system earth, this voltage is not seen by the instrumentation; it is merely a common-mode voltage.

Figure 46 shows the earthing system applied to a number of cabinets. All connections from the SPD busbar are made to a star-point earth on the sub-system earth busbar to minimise the shift in SPD busbar potential when they are daisy-chained together. Links between cabinets and sub-system busbars should be no more than 3m in order to keep the maximum surge-induced voltage across them below the insulation specifications for the instruments.

## 8.7 Hazardous areas – earthing for lightning protection

The subject of the use of electrical/electronic equipment in potentially explosive atmospheres is large and complex, and this publication can therefore only address the earthing of SPDs used in these systems. For more details about surge protection in hazardous areas, consult TAN1004 and TAN1005.

Instances inevitably arise in which a cable links hazardous and safe areas and where there is a chance of an ignition hazard due to flashover in systems where shunt-diode safety barriers are installed (or even galvanic isolators if the local ground potential differences are large enough). See figure 47. The source document for guidance on the subject of hazardous areas in the UK is BS5345. Publications available from Measurement Technology Ltd deal with earthing of intrinsically safe systems.

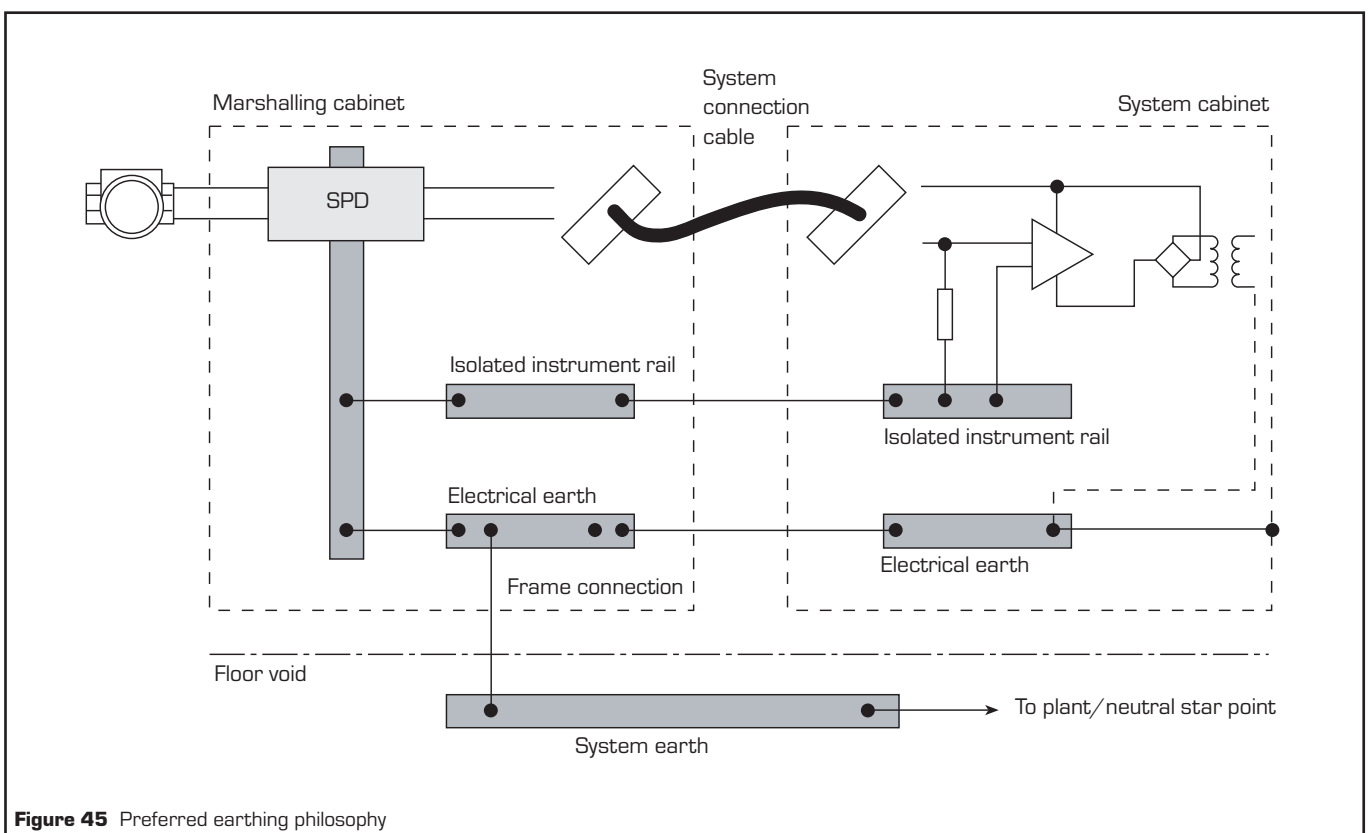
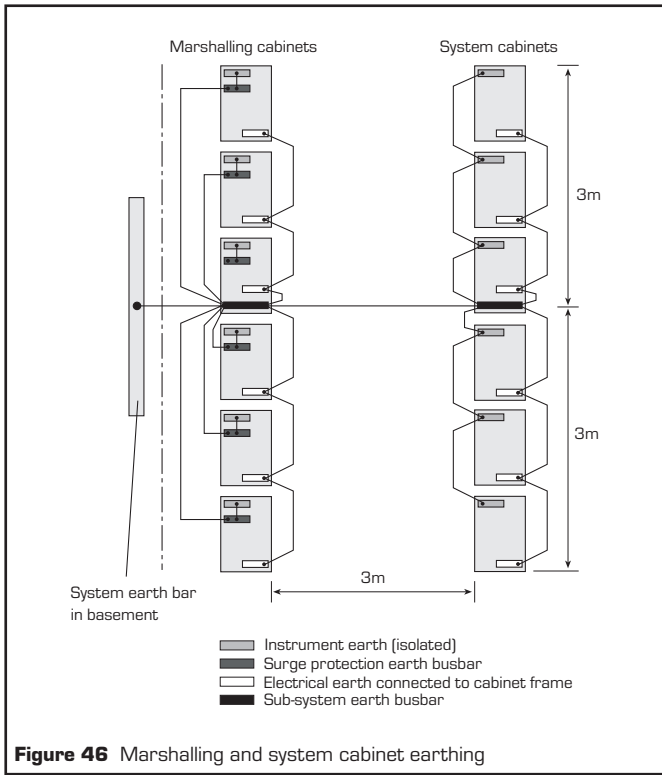

Figure 45 Preferred earthing philosophy



**Figure 46** Marshalling and system cabinet earthing

Good lightning protection practice demands an SPD at each end of the cable with good star-point earths, as in figure 48.

However, according to EN 60079, intrinsically safe circuits should be:-

- a) Insulated from earth, or
- b) earthed at a single point, or
- c) incorporate galvanic isolation where there is more than one earth point, or
- d) in cases where galvanic isolation is not employed, the earths should be bonded using 4mm<sup>2</sup> or greater cross-section insulated cable.

The system, with lightning protection, is shown in figure 49. Note that the bonding cable is unlikely to serve any useful lightning protection function because of its length and consequent impedance.

Earthing is made much easier when, as is increasingly the case, metallic earth mats are laid down. Note that SPDs must be mounted on their own busbar and connection made straight to the star-point earth, otherwise common impedance coupling could couple a surge into intrinsically safe equipment.

Where there is anything more than a negligible risk of lightning occurring – with consequential levels of energy vastly greater than those designed to be present in a hazardous area – then good lightning protection is of paramount importance. The system designer should carefully document his earthing strategy, and, where doubtful, seek the advice of a responsible authority, which, in the UK, is the Health and Safety Executive.

For further reading on the subject, see Appendix C.

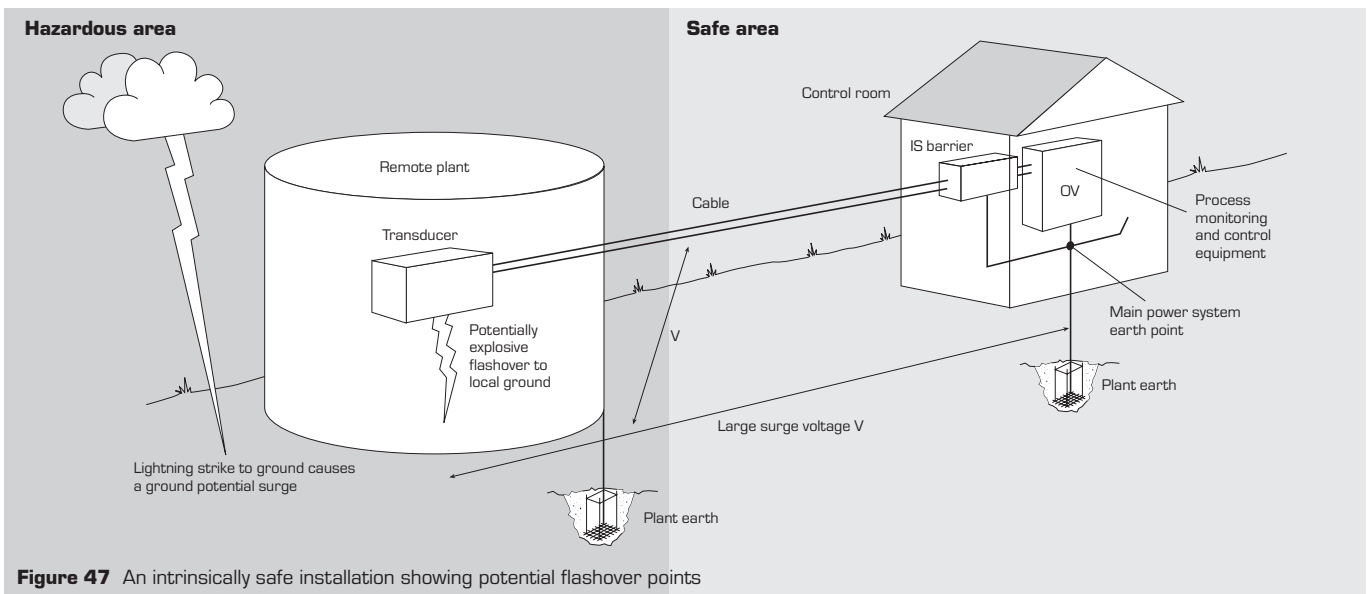

**Figure 47** An intrinsically safe installation showing potential flashover points

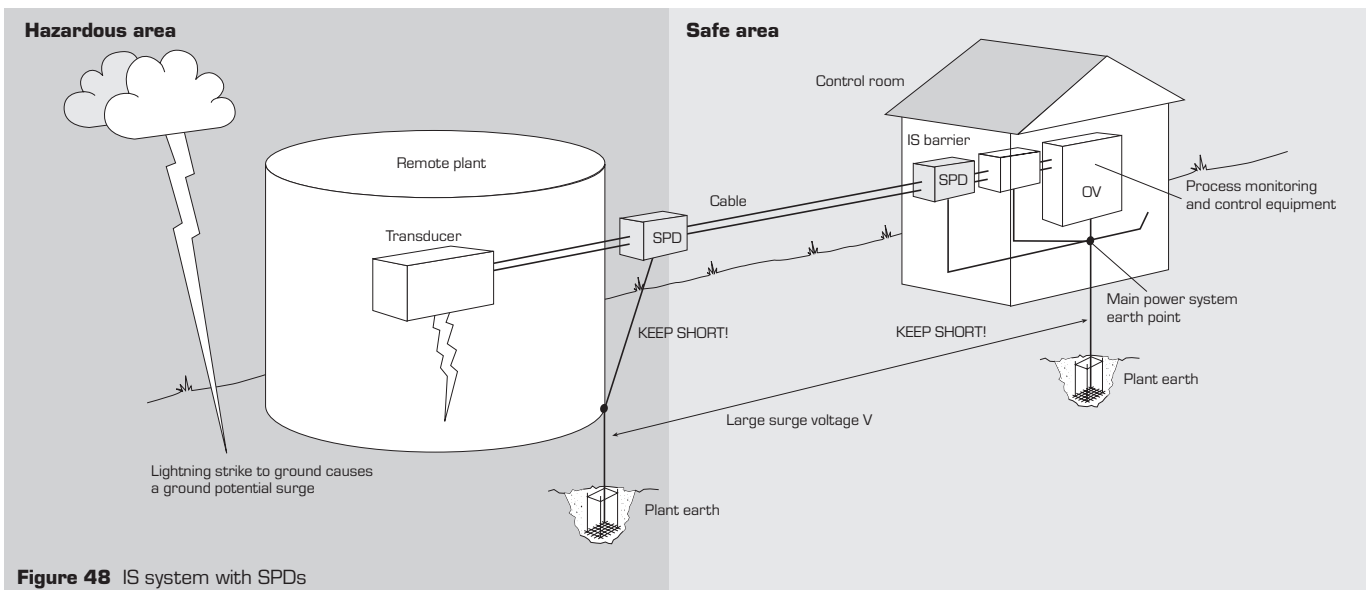

**Figure 48** IS system with SPDs

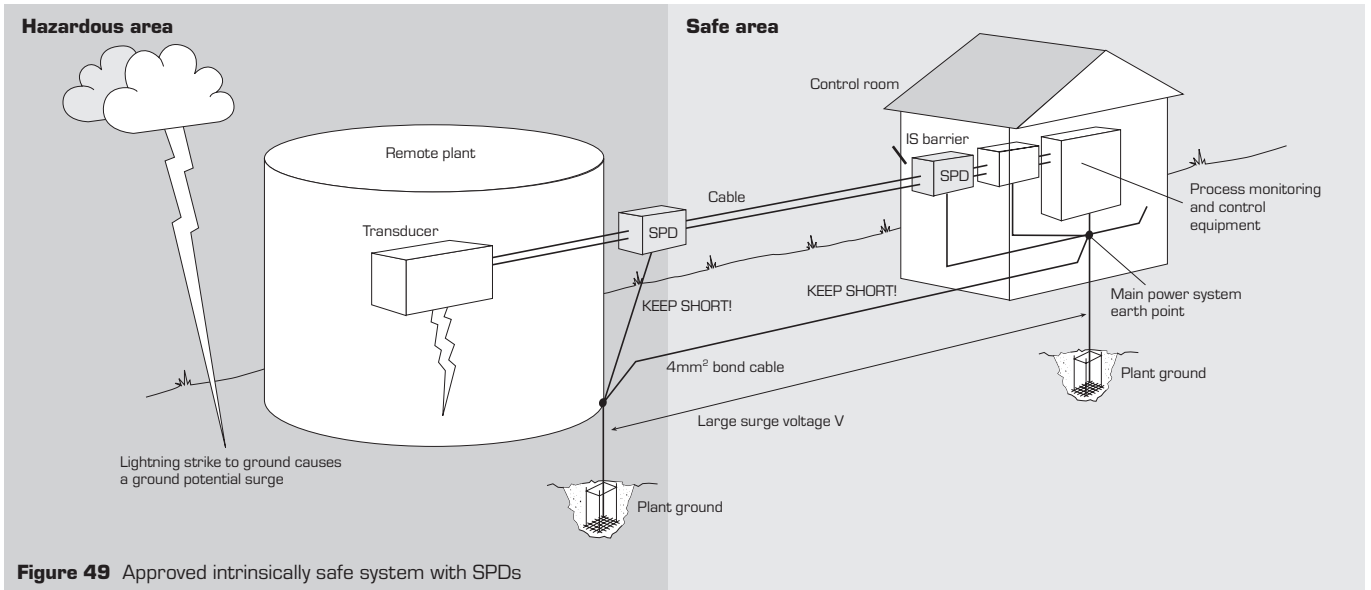

Figure 49 Approved intrinsically safe system with SPDs

## 9 APPENDICES

### 9.A Appendix A – Ground electrode resistance and surge current sharing, a simple model

Although a considerable over-simplification, this model provides useful insight without getting too bogged down in mathematics.

Consider two installations, 1 and 2, linked by a cable, each with a ground electrode system and with one fed from a remote cable (figure 50). A lightning strike causes a surge on the cable relative to local grounds 1 and 2. Installation 1 has an SPD fitted which, in this simple model, is assumed to provide a short circuit for the surge.

The situation can be represented by the circuit diagram reproduced in figure 51. In this,  $V$  is the transient voltage source and  $R$  is the source resistance (including the resistance of the cable).  $R_g$  and  $r_g$  are the ground electrode resistances of installations 1 and 2 respectively and  $r$  is the resistance of the interconnecting cable. For the sake of simplicity, only resistance and not reactance is considered.

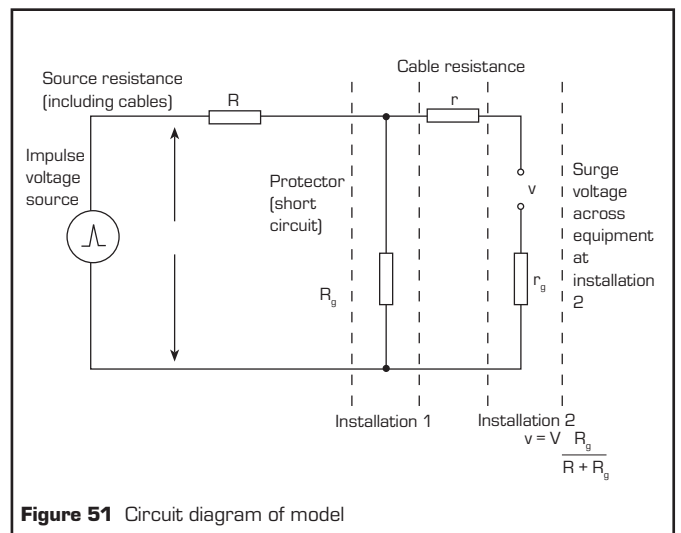

Figure 51 Circuit diagram of model

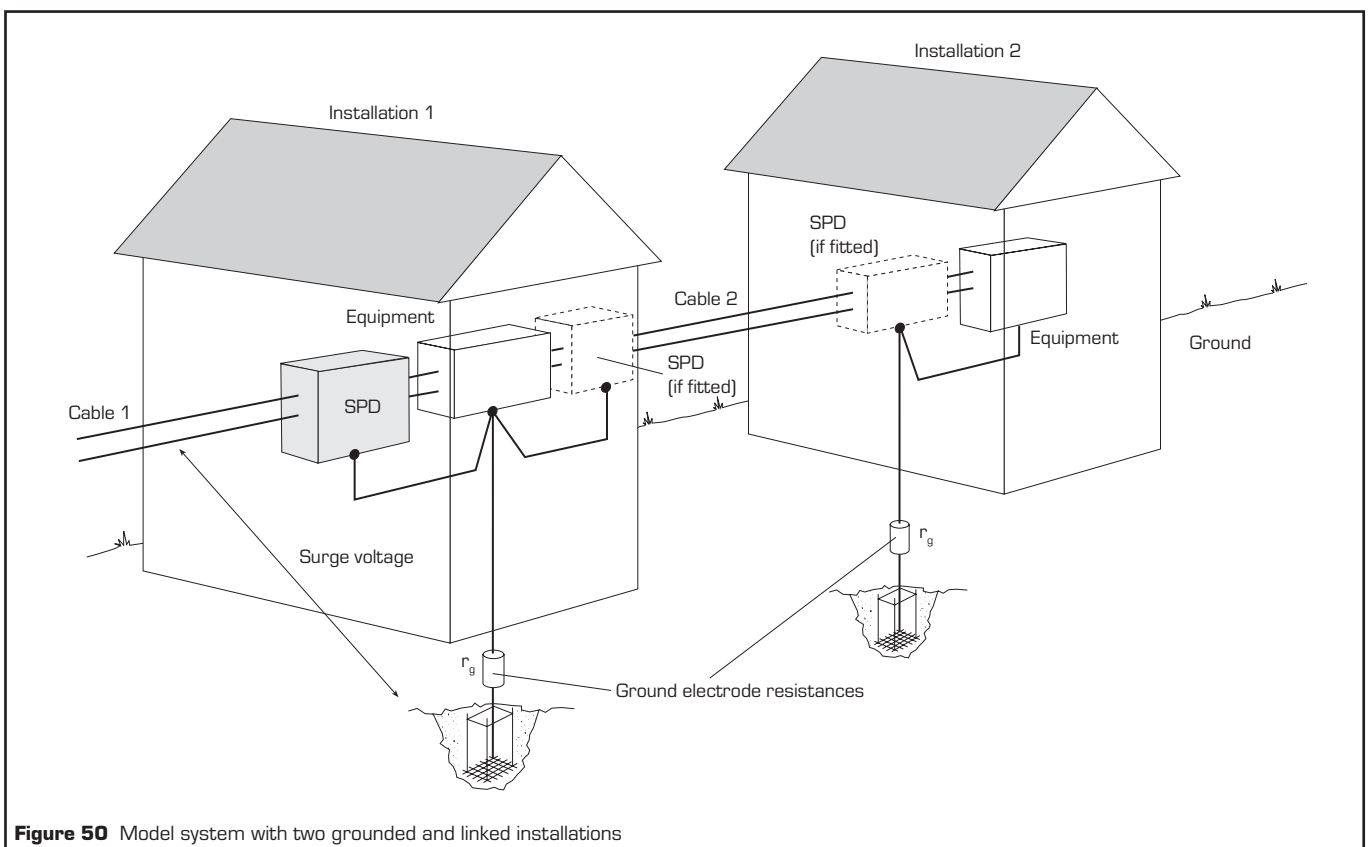

Figure 50 Model system with two grounded and linked installations

First, we assume that installation 2 is unprotected and calculate the surge voltage it receives and then calculate the surge current when an SPD (again acting as a 'perfect' short circuit) is fitted.

From the diagram in figure 51, the received surge voltage is:-

$$v = V \times \frac{R_g}{R+R_g}$$

When the SPD in installation 2 operates, it closely approximates to a short circuit (figure 52).

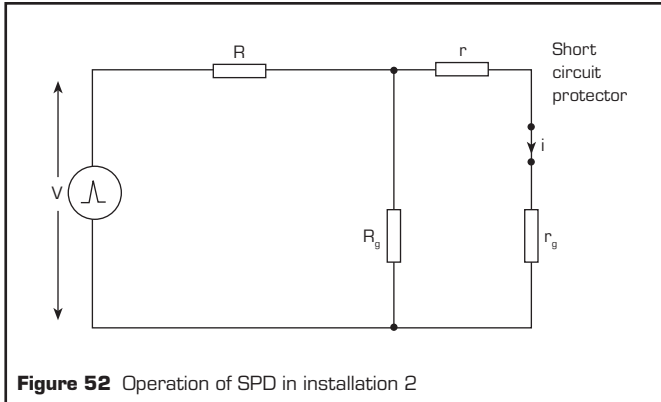

Figure 52 Operation of SPD in installation 2

From figure 53:-

$$i = V \times \frac{R_g}{R(R_g+r+rg)+R_g(r+rg)}$$

$$i = V \times \frac{1}{R(1+[r+rg]/R_g)+(r+rg)}$$

This looks a little obscure, so it is helpful to consider the two extreme cases of no ground electrode and a perfect ground electrode.

No electrode:

$$R_g = \infty$$

$$i = \frac{v}{R+r+rg}$$

Perfect electrode:

$$R_g = 0$$

$$i = 0$$

As might have been expected, the higher the ground resistance at installation 1, the bigger the surge that installation 2 receives.

## 9.B Appendix B – Glossary

### Bonding

Making electrical connections, not necessarily for carrying current but with the intention of ensuring a common potential

### dc

Direct current – in common usage used in 'dc voltage' to describe a uni-directional voltage

### Equipotential zone

An area where people attempt, by providing electrical conductors, to keep equipment at the same potential or voltage. In most practical cases it can be approached – but never reached – since voltage differences appear across conductors when current flows through them.

### GDT

Gas discharge tube.

### Impedance

The property of a conductor which inhibits the flow of current.

### Inductance

The property of a conductor which inhibits changes in current, due to the magnetic field created by the current.

### kA

kiloamp; [1kA = 1000 amperes]

### kV

kilovolt; [1kV = 1000 volts]

### Limiting voltage

The transient safe voltage present at the output of a surge protection device and to which the protected equipment is subjected (often known as 'let-through voltage').

### MOV

Metal oxide varistor.

### SPD

Surge protection device.

### Surge; transient; transient overvoltage

Terms used loosely and interchangeably to indicate the presence of an abnormally high voltage which is present for a brief interval only. In the context of this publication, we are generally referring to surges caused by lightning activity.

### Surge link

A short bonding conductor fitted to limit the voltage between the earth connections of an SPD and the protected equipment.

### Surge protector; surge protection device (SPD); transient protector (see below)

Interchangeable terms for devices which are intended to prevent damage caused by transient voltages.

Other terms for SPDs can be derived (on a 'pick and mix' basis) by combining any one of the words in the left-hand column with any one of those in the right-hand column.

Surge	arrester
Transient	barrier
Overvoltage	suppressor
Lightning	protector
Spike	protection device

### True earth

The point of zero voltage to which the voltage of any other point can be referred. It doesn't exist!

## 9.C Appendix C – Further reading

Lightning (section 2)

Martin A Uman, *Lightning*, Dover 0 486 64575 4, 1969

William C Hart and Edgar W Malone, *Lightning and Lightning Protection*, Interference Control Technologies Inc, 1988

Code of practice for protection of structures against lightning Annex C

Ralph Morrison, *Grounding and Shielding Techniques in Instrumentation*, Wiley Interscience, 0 471 83805 5, date 1986

Henry W Ott, *Noise Reduction Techniques in Electronic Systems*, Wiley Interscience, 0 471 85068 3

Surge earths and telecommunications functional earths (section 8.5)

*Installation of Apparatus Intended for Connection to Certain Telecommunications Systems*, Part 1: 'General Recommendations', BS6701: 1994

Hazardous areas – earthing for lightning protection (section 8.7)

*Surge protection for intrinsically safe systems*, Application Note TAN1004, Telematic Ltd

*Surge protection for Zone 0 Locations*, Application Note TAN1005, Telematic Ltd

**Telematic Limited**

Pondwicks Road, Luton, Beds, UK LU1 3LH  
Tel: +44 (0)1582 429464 Fax: +44 (0)1582 459669  
E-mail: enquiry@telematic.com WWW: www.telematic.com

**A member of the MTL Instruments Group plc**

**Atlantic Scientific Corporation**

4300 Fortune Place, Suite A, W. Melbourne, Florida 32904 USA  
Tel: +1 321 725 8000 Fax: +1 321 727 0736  
E-mail: sales@atlanticscientific.com WWW: www.atlanticscientific.com

**A member of the MTL Instruments Group plc**