

Recommended Cable Dressing

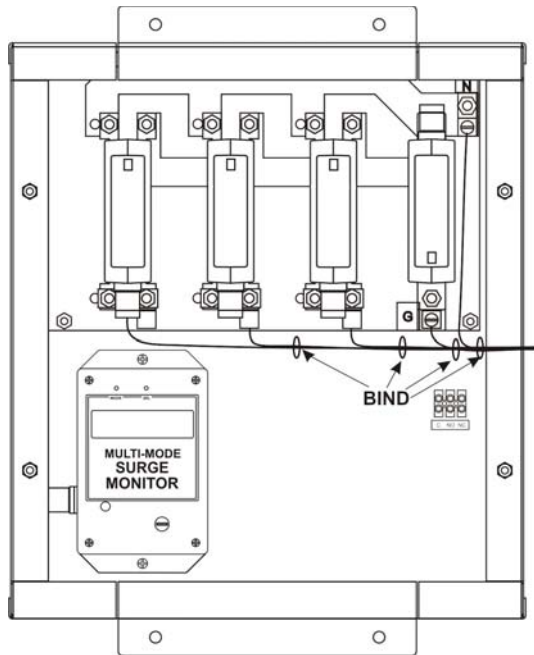
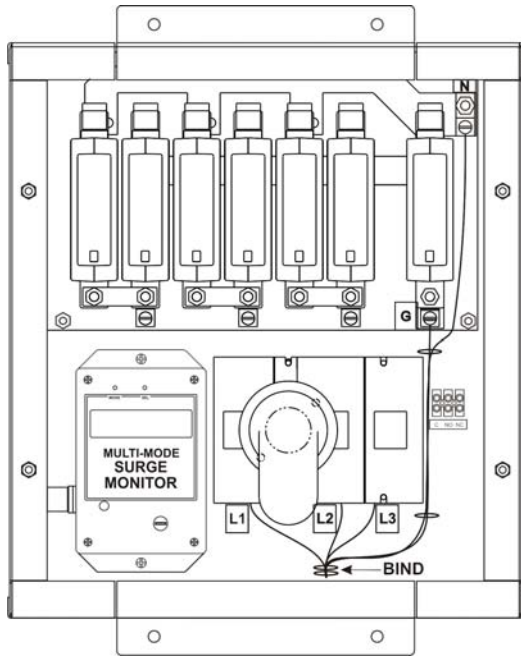

Installation Instructions & User Manual

ZONEMASTER PRO

AC Panel Transient Voltage Surge Suppressors

CONGRATULATIONS! YOU HAVE JUST PURCHASED THE BEST SURGE PROTECTION IN THE INDUSTRY!

Adhering to these instructions guarantees maximum performance of this protection device.

INTRODUCTION

This document explains how to install the *ZoneMaster PRO* AC Panel Surge Protection Devices.

INSTALLATION INSTRUCTIONS

Warning: Terminals marked L1, L2, L3, N, GND (where relevant) must be connected respectively to phase(s) neutral and ground. Failure to comply may result in personal injury or equipment damage. See corresponding diagrams for proper connections.

INSTALLATION DESCRIPTION

ZoneMaster PRO units are connected in parallel (“shunt”) across the supply to be protected. The connecting cable does not carry the supply current, only the current associated with suppressing the transient overvoltage.

MOUNTING

The unit should be mounted **as close as possible** to the panel to be protected. Conduit, preferably metallic, is to be installed from the suppressor to the panel. Determine a location where the connection wires will be installed and then drill a suitable hole in the *ZoneMaster PRO* enclosure.

INCORRECT INSTALLATION WILL IMPAIR THE EFFECTIVENESS OF THE AC PANEL PROTECTORS.

CONNECTING LEADS

Connect the suppressor as shown in the installation diagram. Connect the terminals within the suppressor to the load side of 60A breakers or fuses within the panel. See specific connection diagrams for more details and markings on unit if provided.

RECOMMENDED WIRE GAUGE - STRANDED COPPER

Minimum of 8 AWG

Maximum of 4 AWG (for ease of dressing)

Torque Rating: 35 - 50 in - lbs.

LENGTH OF CONNECTING LEADS

The longer the connecting leads between the *ZoneMaster PRO* and power panel, the higher the residual transient voltage.

RECOMMENDED MAXIMUM: 500mm (19")

IDEALLY: 250mm (10")

Each 250mm increase in cable length increases clamping voltage by 25V per 1000A surge current discharged.

OPERATION

The *ZoneMaster PRO* Series Surge Protection System requires little or no operator intervention after installation. The units are provided with a multi-mode surge monitor that provides fault status (audible and visual) and a surge counter that counts how many transients the unit has suppressed.

Normally the counter displays the number of surges counted. In the event of a module failure, the display changes to MODULE FAILURE and an audible alarm will sound. See page 5 for trouble shooting/repair.

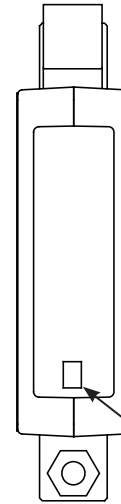

STATUS INDICATORS

The *ZoneMaster PRO* units have comprehensive, continuous visual status monitoring present on each module.

Status Indicated	Full Protection Present	Reduced (Standby) Protection	No Protection	No Power to Protector	High N-G Voltage*
LED Indicator	Green LED Lit	Red LED Lit	Red LED Lit	Green LED Out	Red & Green LED Lit

REMOTE INDICATORS

A remote indication of the reduced protection state is available as a normally open or normally closed dry contact “Form C”. Rated maximum 1A at 30Vdc resistive and maximum 0.3A at 125Vac (30VA dc or 37.5VA ac) general use. Suitable for connection of AVL2 18AWG to 20AWG copper wire. Recommended tightening torque: 7 in - lbs.

Routing of these wires should be separate from the power with a minimum of spacing of two inches.

***WARNING:**

OF HIGH NEUTRAL TO GROUND VOLTAGE

On certain models, if both Red and Green lights are on, consult a qualified electrical contractor to check the integrity of the building wiring.

INSTALLATION DIAGRAMS

**240V Three Phase 3W DELTA
480V Three Phase 3W DELTA**

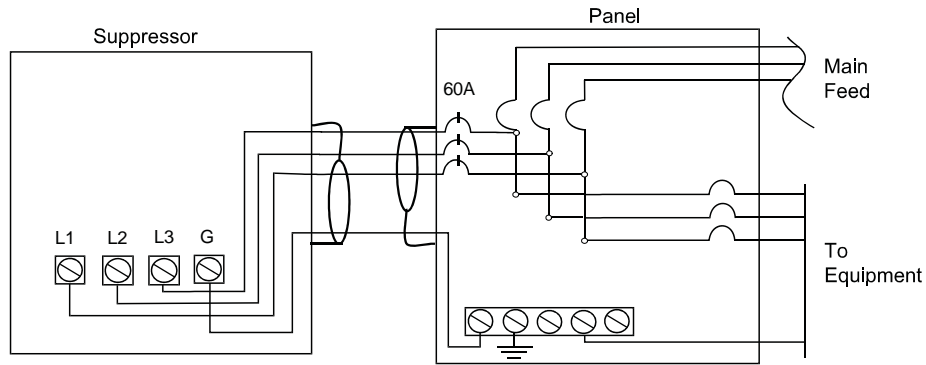

Figure 1

**120/208V Three Phase 4W WYE
120/240V Three Phase 4W DELTA (HL = L2)
277/480V Three Phase 4W WYE
240/415V Three Phase 4W WYE
220/380V Three Phase 4W WYE**

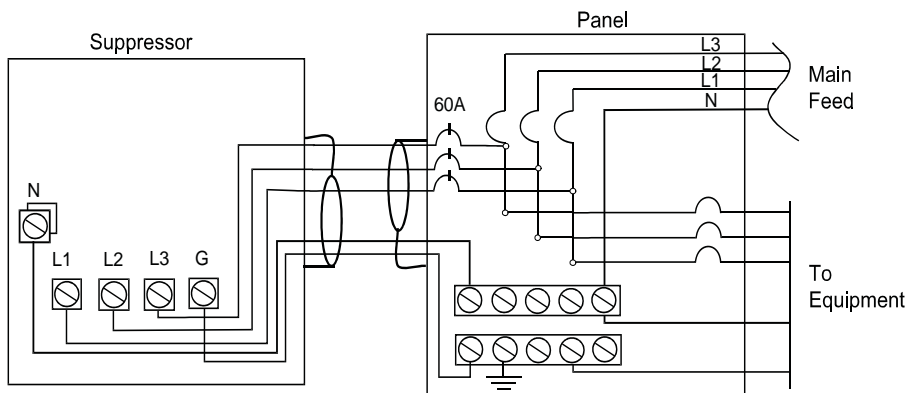

Figure 2

120/240V Split Phase 3W

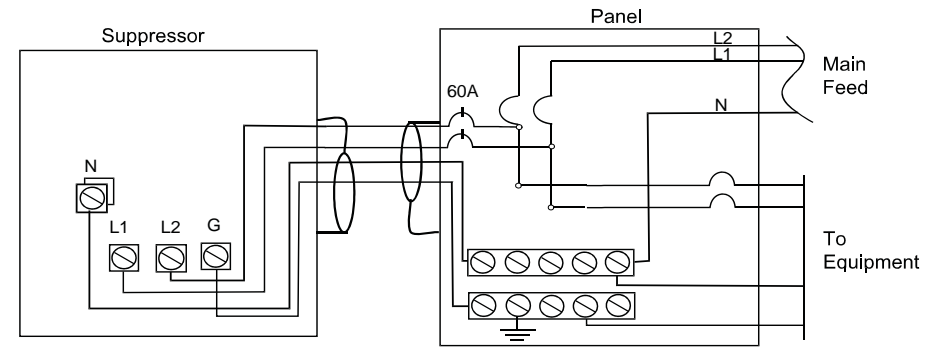

Figure 3

TROUBLESHOOTING/REPAIR

WARNING -- ONLY QUALIFIED PERSONNEL SHOULD PERFORM MAINTENANCE ON THIS UNIT. HAZARDOUS VOLTAGES ARE PRESENT INSIDE THE UNIT DURING NORMAL OPERATIONS. ELECTRICAL SAFETY PRECAUTIONS MUST BE FOLLOWED WHEN SERVICING THIS UNIT. TO PREVENT RISK OF ELECTRICAL SHOCK, TURN OFF AND LOCK OUT ALL POWER SOURCES TO THE UNIT BEFORE SERVICING.

Remove the cover and determine which module has failed by reviewing the LED status indication window (see page 7 'Status Indicators') then disconnect the power. Next, disconnect the remote monitoring plug located on top of the module. Then use a 7/16" socket wrench or nutdriver to remove the nuts that hold the module in place. Replace module with same type and color code. Replace nuts and tighten securely. **DO NOT OVERTIGHTEN.** Insert remote monitoring plug. Install cover, restore power and check for normal operation.

UNITS WITH INTERNAL DISCONNECT

The disconnect handle is mounted to the inside of the enclosure cover. Slide it from the tie-wraps and insert square end into disconnect switch. When complete, remove handle from switch and slide it back into place on the cover. Reinstall enclosure cover.

EXTERNAL HANDLED DISCONNECT UNITS

Located on the cover is the LED status indication of each module (see page 7 'Status Indicators'). Determine which module has failed then disconnect power and remove the cover. Next, disconnect the remote monitoring plug located on top of the module. Then use a 7/16" socket wrench or nutdriver to remove the nuts that hold the module in place. Replace module with same type and color code. Replace nuts and tighten securely. **DO NOT OVERTIGHTEN.** Insert remote monitoring plug. Install cover, restore power and check for normal operation.

SETTING SURGE MONITOR MODES OF OPERATION

The following is displayed upon power-up and when in monitor mode. To change monitor options, push the mode button. This will step through the different program modes. To reset the surge count, hold down both the mode and select buttons for about 5 seconds. The count will be set to zero.

M	o	n	i	t	o	r		M	o	d	e				
S	u	r	g	e	C	o	u	n	t	=	0	0	0	0	0

PROGRAM MODE - ALARM

P	r	o	g	r	a	m		M	o	d	e				
A	l	a	r	m	=	O	N								

ON: The surge monitor will detect the module status and display “Module Failure” if a module fails.

OFF: The surge monitor does not give a module status and the audio option is disabled.

WARNING: If remote monitoring from a different source is desired, the alarm option must be set to OFF and the connector on the surge monitor disconnected. Failure to do so will cause damage to the surge monitor and possibly to the connected monitoring equipment.

PROGRAM MODE – AUDIO

P	r	o	g	r	a	m		M	o	d	e				
A	u	d	i	o	=	O	N								

ON: The alarm will sound for about 2 seconds if a surge is detected. If a module fails the alarm will sound continuously until either the mode or select button is pushed.

OFF: No alarm is sounded and only the display will indicate that a module has failed or a surge was detected.

PROGRAM MODE – SENSITIVITY

(Typical 8/20µs impulse)

P	r	o	g	r	a	m		M	o	d	e				
S	e	n	s	i	t	i	v	i	t	y	=	2	0	0	A

Display will read - *200A or *500A

*Level at which counter will register a surge count.

Press mode again to return to monitor mode.

- **BIND THE PHASE, NEUTRAL AND GROUND CONDUCTORS TIGHTLY, OVER THE ENTIRE RUN FROM THE SUPPRESSOR TO THE SERVICE PANEL.**
- **ALWAYS USE THE SHORTEST LENGTH OF CONNECTING CABLE POSSIBLE.**

CONNECTION

WARNING: VERIFY THAT ALL POWER CIRCUITS ARE DE-ENERGIZED AND LOCKED OUT BEFORE MAKING ELECTRICAL CONNECTIONS.

Before making connections to the unit, verify that the *ZoneMaster PRO* service rating is appropriate for connection to the intended electrical service. Each *ZoneMaster PRO* has terminal lugs that are marked L1, L2, L3, N and G where appropriate. See figures 1, 2 or 3, depending on the model of the *ZoneMaster PRO*.

SURGE COUNTER CT

Any wire can be inserted through the “CT”. The most common installations are through the neutral or ground wires.

WARNING — Connect the high-leg or wild-leg to terminal L2 when installing the unit on a high-leg delta electrical service. Mis-installation will cause the suppressor to fail upon power-up.

CONNECTING THE SPD TO THE BUS IN THE SWITCHGEAR OR MCC:

Connect #2AWG to #6AWG ground and neutral (if applicable) conductors between the buss bar lugs in the SPD to the ground and neutral busses in the switchboard. Connect the phase conductors to the SPD buss bar terminals and/or disconnect with the appropriate size conductors. SPD’s that do not utilize an internal disconnect must be provided with a means of removing power to the device for servicing. It is important to keep all connecting leads as short as possible. Additionally, conductors should be twisted together for as much of the wire run as possible. If larger phase conductors are specified, a molded case circuit breaker that can utilize the larger cables must be supplied as an option.